

Knot Categorification

from Mirror Symmetry, via String Theory

Mina Aganagic

UC Berkeley

I will describe
two geometric approaches to the
knot categorification problem,
which come out of string theory.

A key new aspect of both approaches
is that it is manifest that decategorification
gives back the quantum link invariants
one set out to categorify.

Relation between the two approaches
is a variant of
two dimensional mirror symmetry.

Mirror symmetry, and tools developed to study it,
play a central role.

Elements of these approaches have
been discovered by mathematicians earlier,
notably in the works of
Kamnitzer and Cautis,
Seidel and Smith, and others.

There is a third approach
with the same string theory origin,
due to Witten.

What emerges from string theory
is **unified framework**
for **knot categorification**.

The story I will tell you about is subject of three papers:

Knot Categorification from Mirror Symmetry

Part I: Coherent sheaves, 2004.14518

Part II: Lagrangians, 2008.XXXX

Part III: String theory origin, 2009.XXXX

and a series of lectures:

UCLA Distinguished Lecture Series

<https://www.math.ucla.edu/dls/mina-aganagic>

To begin with, it is useful to recall
some well known aspects of knot invariants.

A quantum invariant of a link

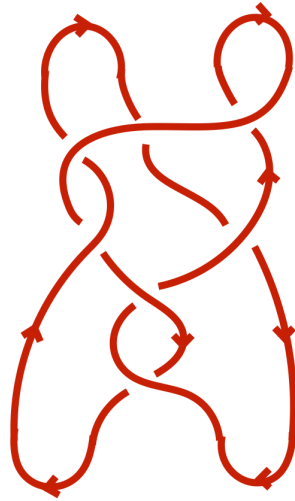

depends on a choice of a Lie algebra,

$$L\mathfrak{g}$$

and a collection of representations of $L\mathfrak{g}$
coloring its strands.

The link invariant,
in addition to the choice of the Lie algebra

$$L\mathfrak{g}$$

and its representations,
depends on one parameter

$$q = e^{\frac{2\pi i}{\kappa}}$$

Edward Witten explained in '89 that,
this quantum link invariant comes from

Chern-Simons theory with gauge group based on the Lie algebra

$$L\mathfrak{g}$$

and (effective) Chern-Simons level

$$\kappa$$

In the same paper he also showed that
underlying Chern-Simons theory is a
two-dimensional conformal field theory associated to

$$L\mathfrak{g} \quad \text{and} \quad \kappa$$

We can take this, rather than Chern-Simons theory, as the starting point.

The conformal field theory one needs has an

affine Lie algebra symmetry

$$\widehat{L\mathfrak{g}}_{\kappa}$$

obtained as the central extension of the loop algebra of $L\mathfrak{g}$

where one fixes the central element to be κ

We will begin by reviewing the relation of conformal field theory to quantum knot invariants.

Then, we will explain how the entire structure and its categorification emerges from geometry.

To eventually get invariants of knots in \mathbb{R}^3 or S^3

we want to start with a Riemann surface

A

which is a complex plane with punctures.

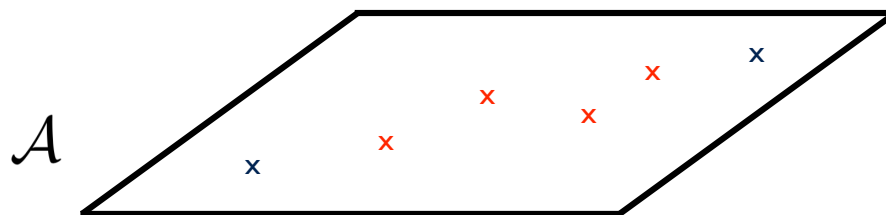

It is equivalent, but better for our purpose,

to take

A

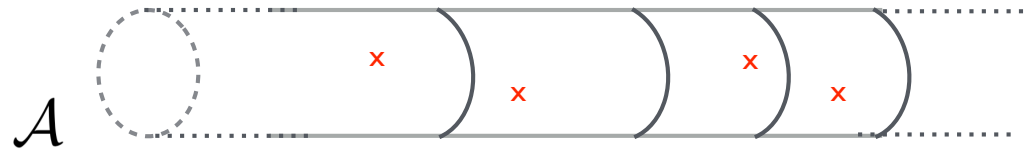

to be a punctured infinite cylinder.

To punctures at finite point

$$x = a_i$$



we will associate finite dimensional representations

$$V_i$$

of $L\mathfrak{g}$.

To punctures at the two ends at infinity,

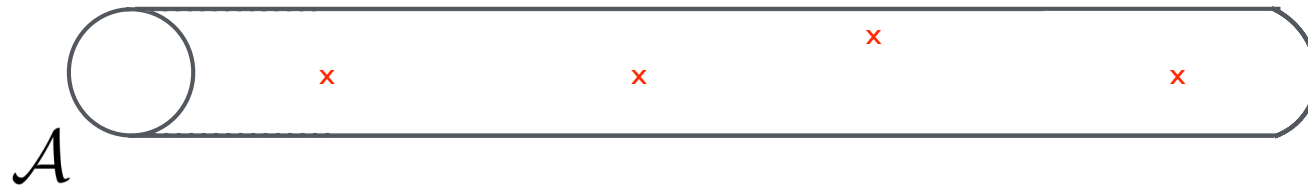

we will associate a pair of

infinite dimensional, Verma module representations,

whose highest weight vectors

$$|\lambda\rangle \quad |\lambda'\rangle$$

are given by generic weights of $L_{\mathfrak{g}}$.

The Riemann surface

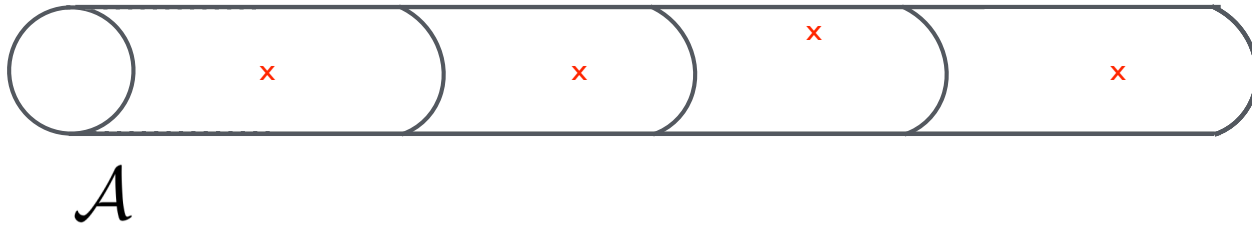

can be obtained by sewing from



3-punctured spheres.

To a 3-punctured sphere



conformal field theory associates a chiral vertex operator

$$\Phi_{V_i}(a_i) : V_{\lambda_i} \rightarrow V_i(a_i) \otimes V_{\lambda_{i+1}}$$

which acts as intertwiner between pairs of Verma module representations.

To a Riemann surface with punctures
conformal field theory associates

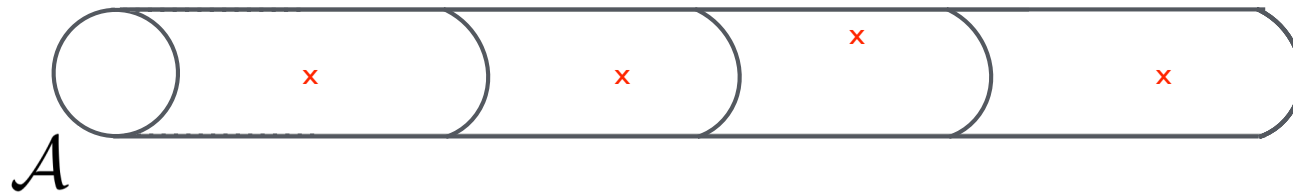

a conformal block

$$\langle \lambda | \Phi_{V_1}(a_1) \cdots \Phi_{V_\ell}(a_\ell) \cdots \Phi_{V_n}(a_n) | \lambda' \rangle$$

obtained by sewing chiral vertex operators.

In sewing chiral vertex operators

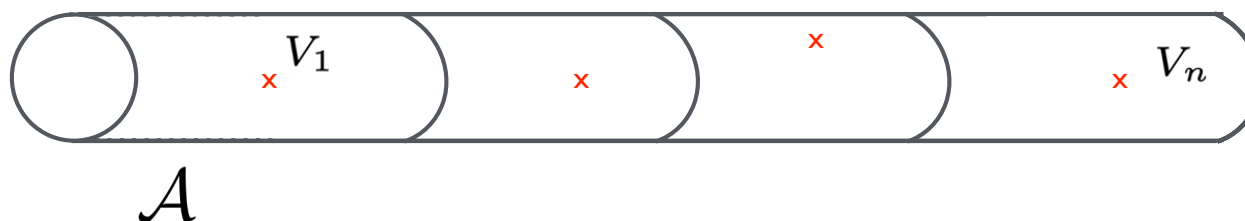

we get to make choices of intermediate Verma module representations,

so we get a vector space of conformal blocks,

whose dimension turns out to be that of

the subspace of $L\mathfrak{g}$ representation

$$V = \bigotimes_{i=1}^n V_i$$

with fixed weight $\nu = \lambda - \lambda'$

By varying positions of vertex operators on \mathcal{A} as a function of

“time” $s \in [0, 1]$

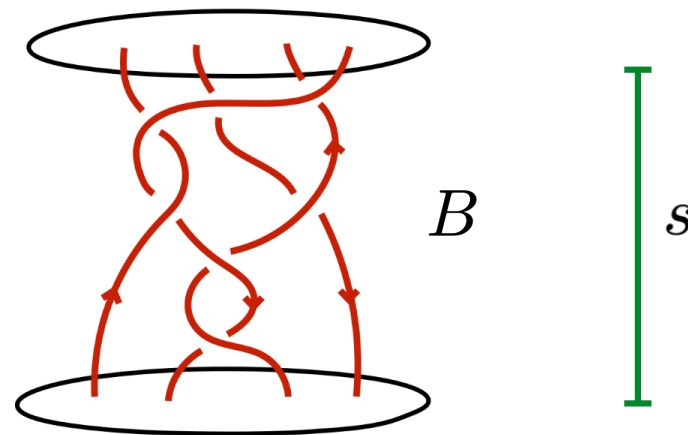

we get a colored braid in three dimensional space

$\mathcal{A} \times [0, 1]$

The braid invariant

$$\mathfrak{B} = \mathfrak{B}(B)$$

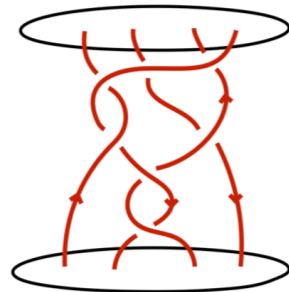

is a matrix that transports
the space of conformal blocks,
along the braid B

To describe the transport,
instead of characterizing $\widehat{L} \mathfrak{g}_\kappa$ conformal blocks

$$\langle \lambda | \Phi_{V_1}(a_1) \cdots \Phi_{V_\ell}(a_\ell) \cdots \Phi_{V_n}(a_n) | \lambda' \rangle$$

in terms of vertex operators and sewing,

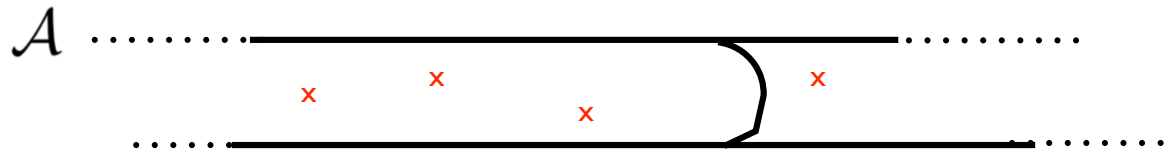

it is better to describe them as solutions to a differential equation.

The equation solved by conformal blocks of $\widehat{L\mathfrak{g}}_\kappa$ on \mathcal{A}

$$\mathcal{V}(a_1, \dots, a_\ell, \dots, a_n) = \langle \lambda | \Phi_{V_1}(a_1) \cdots \Phi_{V_\ell}(a_\ell) \cdots \Phi_{V_n}(a_n) | \lambda' \rangle$$



is the equation discovered by Knizhnik and Zamolodchikov in '84:

$$\kappa a_\ell \frac{\partial}{\partial a_\ell} \mathcal{V} = \sum_{j \neq \ell} r_{\ell j}(a_\ell/a_j) \mathcal{V}.$$

The equation makes sense for any $\kappa \in \mathbb{C}$, not necessarily integer.

The quantum braid invariant

$$\mathfrak{B}(B)$$

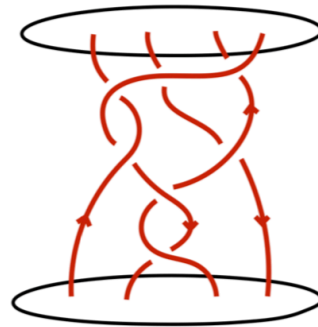

is the monodromy matrix of the Knizhnik-Zamolodchikov equation,
along the path in the parameter space corresponding to
the braid B ,

The monodromy problem of the $\widehat{L\mathfrak{g}}_\kappa$ Knizhnik-Zamolodchikov equation

$$\kappa a_\ell \frac{\partial}{\partial a_\ell} \mathcal{V} = \sum_{j \neq \ell} r_{\ell j}(a_\ell/a_j) \mathcal{V}.$$

was solved by Tsuchia and Kanie in '88 and, Drinfeld and Kohno in '89.

They showed that its monodromy matrices are given in terms of the
R-matrices of the quantum group

$$U_q({}^L\mathfrak{g})$$

corresponding to ${}^L\mathfrak{g}$

Action by monodromies

turns the space of conformal blocks into a module for the

$$U_q({}^L\mathfrak{g})$$

quantum group in representation,

$$V = \bigotimes_{i=1}^n V_i$$

The representation V_i is viewed here as a representation of $U_q({}^L\mathfrak{g})$ and not of ${}^L\mathfrak{g}$, but we will denote by the same letter.

The monodromy action
is irreducible only in the subspace of

$$V = \bigotimes_{i=1}^n V_i$$

of fixed

weight $\nu = \lambda - \lambda'$

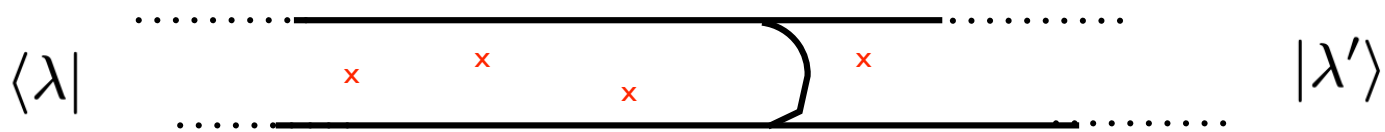

corresponding to conformal blocks of the form

$$\langle \lambda | \Phi_{V_1}(a_1) \cdots \Phi_{V_\ell}(a_\ell) \cdots \Phi_{V_n}(a_n) | \lambda' \rangle$$

This perspective leads to
quantum invariants of not only braids
but knots and links as well.

Any link K can be represented as a

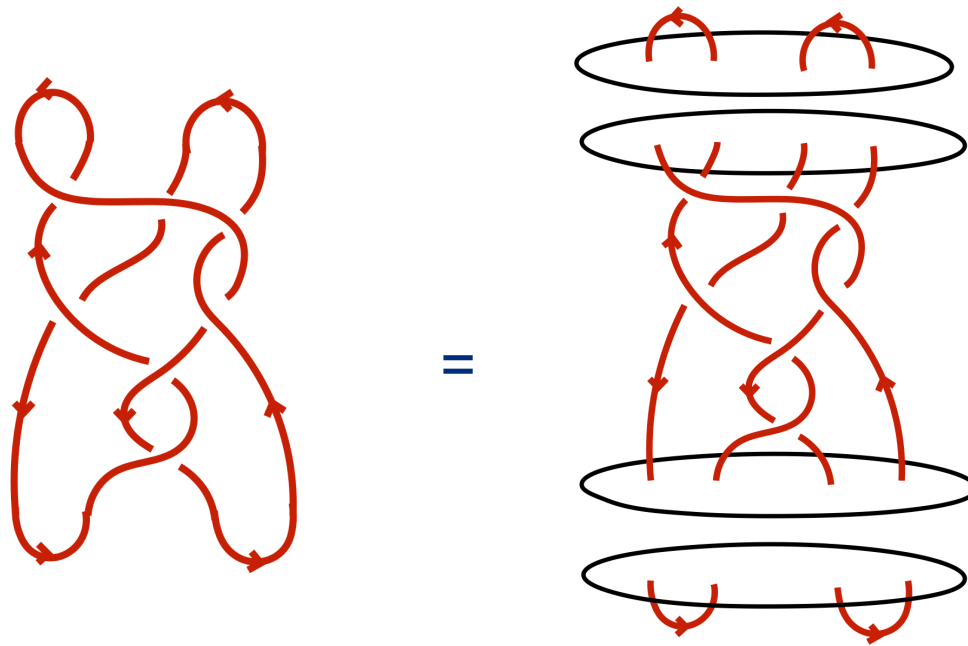

a closure of some braid.

The corresponding **quantum link invariant** is the matrix element

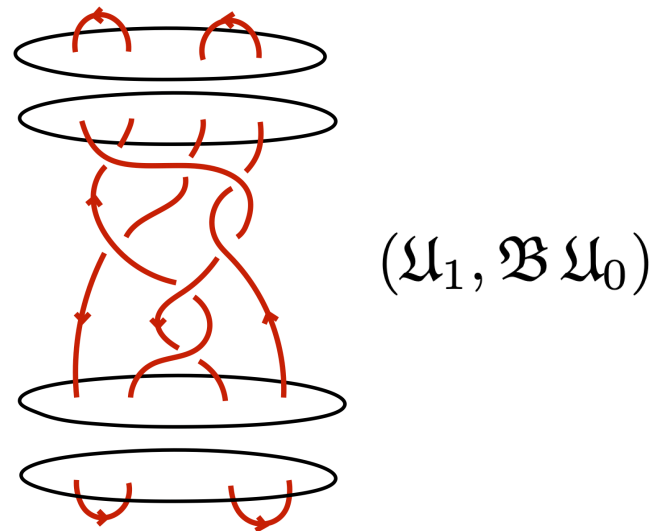

of the braiding matrix,
taken between a pair of conformal blocks
which correspond to the top and the bottom of the picture.

The conformal blocks

we need are very special solutions to KZ equations



which describe pairs of vertex operators,
colored by complex conjugate representations
which come together, fuse, and disappear.

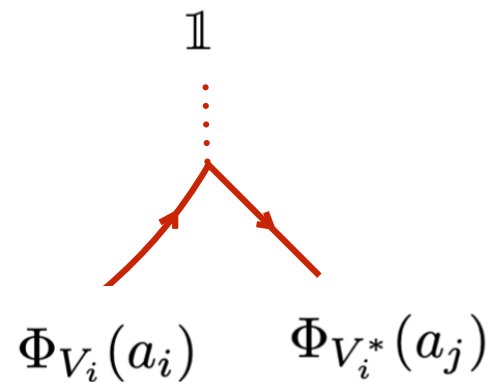

This way,

both braiding and fusion of conformal field theory

$$\Phi_{V_i}(a_i) \otimes \Phi_{V_j}(a_j)$$

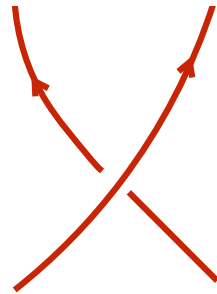

$$\Phi_{V_k}(a_j)$$

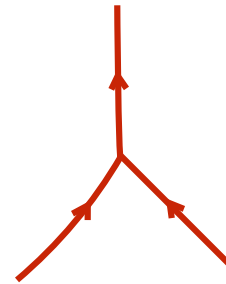

$$\Phi_{V_j}(a_j) \otimes \Phi_{V_i}(a_i)$$

$$\Phi_{V_j}(a_j) \otimes \Phi_{V_i}(a_i)$$

play an important role in the story.

To categorify quantum knot invariants,
one would like to associate
to the space conformal blocks one obtains at a fixed time slice

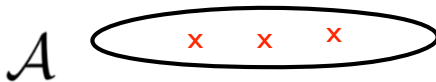

a bi-graded category,
and to each conformal block an object of the category.

To braids,

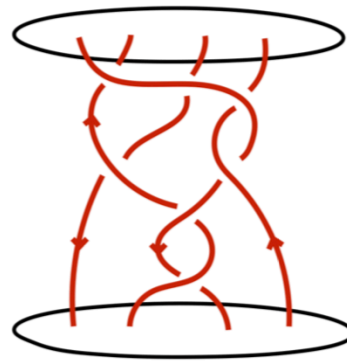

one would like to associate
functors between the categories
corresponding to the
top and the bottom.

Moreover,
we would like to do that in the way that
recovers quantum link invariants upon
de-categorification.

One typically proceeds by coming up with a category,
and then one has to work to prove
that de-categorification gives
the invariants one set out to categorify.

The virtue of the two of the approaches
I will describe in these lectures,
is that the second step is automatic.

I will start by describing the two
approaches we end up with,
and the relation between them
in a manner that is more or less self contained.

Later on,

I will describe their superstring theory origin
and show it is the same as in Witten's approach.

The starting point for us is
a geometric realization
Knizhnik-Zamolodchikov equation.

We will specialize ${}^L\mathfrak{g}$ to be a simply laced Lie algebra

so ${}^L\mathfrak{g} = \mathfrak{g}$ are one of the following types:



The generalization to non-simply laced Lie algebras involves an extra step, which we will not have time to describe.

It turns out that Knizhnik-Zamolodchikov equation of

$$\widehat{L\mathfrak{g}}$$

is the “quantum differential equation” of a certain holomorphic symplectic manifold.

This result has been proven recently by Ivan Danilenko, in his thesis.

Quantum differential equation of a Kahler manifold \mathcal{X}

is an equation for flat sections

$$a_i \frac{\partial}{\partial a_i} \mathcal{V} - C_i \star \mathcal{V} = 0$$

of a connection on a vector bundle with fibers $H^*(\mathcal{X})$.

over the complexified Kahler moduli space.

The connection is defined in terms of “quantum multiplication” by divisors

$$C_i \in H^2(\mathcal{X})$$

Quantum multiplication used in the connection is a product on $H^*(\mathcal{X})$

$$\langle \alpha \star \beta, \gamma \rangle = \sum_{d \geq 0, d \in H^2(\mathcal{X})} (\alpha, \beta, \gamma)_d a^d$$

defined in terms of Gromov-Witten theory or,
the topological A-model of \mathcal{X}

The first, $d = 0$ term of the quantum multiplication

$$\langle \alpha \star \beta, \gamma \rangle = \sum_{d \geq 0, d \in H^2(\mathcal{X})} (\alpha, \beta, \gamma)_d a^d$$

is the classical product on $H^*(\mathcal{X})$:

$$(\alpha, \beta, \gamma)_0 = \int_{\mathcal{X}} \alpha \wedge \beta$$

subsequent $d > 0$ terms are quantum corrections.

Just as Knizhnik-Zamolodchikov equation
is central for many questions in **representation theory**,
quantum differential equation
is central for many questions in
algebraic geometry and in **mirror symmetry**.

We will be discovering here a **new connection** between the two.

To get the quantum differential equation

$$a_i \frac{\partial}{\partial a_i} \mathcal{V} - C_i \star \mathcal{V} = 0$$

to coincide with the Knizhnik-Zamolodchikov equation

$$\kappa a_\ell \frac{\partial}{\partial a_\ell} \mathcal{V} = \sum_{j \neq \ell} r_{\ell j}(a_\ell/a_j) \mathcal{V}.$$

solved by conformal blocks of $\widehat{L\mathfrak{g}_k}$,

$$\mathcal{V}(a_1, \dots, a_\ell, \dots, a_n) = \langle \lambda | \Phi_{V_1}(a_1) \cdots \Phi_{V_\ell}(a_\ell) \cdots \Phi_{V_n}(a_n) | \lambda' \rangle$$

one wants to take \mathcal{X} to be a very special manifold.

The manifold

\mathcal{X}

we need can be described as the moduli space of

singular G monopoles, with prescribed Dirac singularities, on

$$\mathbb{R}^3 = \mathbb{R} \times \mathbb{C}$$

where G is the Lie group of adjoint type with Lie algebra \mathfrak{g}

For every vertex operator

$$\Phi_{V_i}(a_i)$$



we take a singular G monopole

at the corresponding point on \mathbb{R} in $\mathbb{R}^3 = \mathbb{R} \times \mathbb{C}$



$$y_i = \log |a_i|$$

and place it at the origin of \mathbb{C} .

Monopole charge is the highest weight of the $L_{\mathfrak{g}}$ representation V_i .

The total monopole charge,



including that of smooth monopoles is the

weight ν

of the subspace of representation

$$V = \bigotimes_{i=1}^n V_i$$

which the conformal blocks transform in.

Our manifold \mathcal{X} has several other useful descriptions.

The best known one is as a resolution of

$$\mathcal{X} = \text{Gr}^{\vec{\mu}}_{\nu}$$

of intersection of certain slices in affine Grassmannian of G

$$\text{Gr}_G = G((z))/G[[z]]$$

Here, the vector $\vec{\mu}$

encodes the singular monopole charges in order they appear

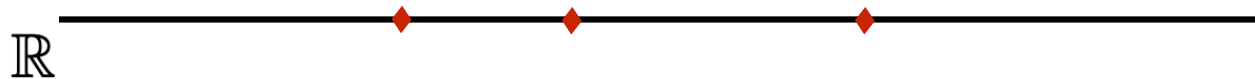

and ν is the total monopole charge.

All the ingredients in

$$\mathcal{V}(a_1, \dots, a_\ell, \dots, a_n) = \langle \lambda | \Phi_{V_1}(a_1) \cdots \Phi_{V_\ell}(a_\ell) \cdots \Phi_{V_n}(a_n) | \lambda' \rangle$$

have a geometric interpretation in terms of \mathcal{X} ,
starting with the (relative) positions of vertex operators on \mathcal{A}

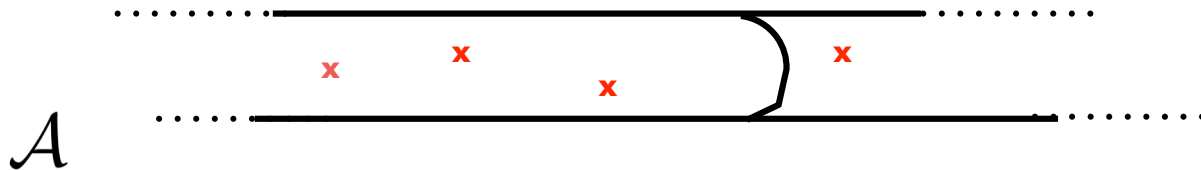

which are the complexified Kahler moduli of \mathcal{X} .

Since \mathcal{X} is holomorphic symplectic,
its quantum cohomology is trivial,
unless we work equivariantly with respect to a torus action
that scales the holomorphic symplectic form

$$\omega^{2,0} \rightarrow \mathfrak{q} \omega^{2,0}$$

We chose all the singular monopoles to be at the origin of

$$\mathbb{C} \quad \text{in} \quad \mathbb{R} \times \mathbb{C}$$

in order for this to be symmetry.

One works equivariantly with respect to a full torus of symmetries

$$T = \Lambda \times \mathbb{C}_q^\times$$

The equivariant parameters for

$$\Lambda \subset T$$

preserving the holomorphic symplectic form,

determine the highest weight vector of Verma module $\langle \lambda |$ in

$$\mathcal{V}(a_1, \dots, a_\ell, \dots, a_n) = \langle \lambda | \Phi_{V_1}(a_1) \cdots \Phi_{V_\ell}(a_\ell) \cdots \Phi_{V_n}(a_n) | \lambda' \rangle$$

The fact that Knizhnik-Zamolodchikov equation solved by

$$\mathcal{V}(a_1, \dots, a_\ell, \dots, a_n) = \langle \lambda | \Phi_{V_1}(a_1) \cdots \Phi_{V_\ell}(a_\ell) \cdots \Phi_{V_n}(a_n) | \lambda' \rangle$$

has a geometric interpretation as the
quantum differential equation of

\mathcal{X}

computed by \mathbb{T} -equivariant Gromov-Witten theory,
implies the conformal blocks too have a geometric interpretation.

Solutions of the quantum differential equation are
equivariant counts of holomorphic maps



of all degrees computed by the A-model on \mathcal{X}
working equivariantly with respect to \mathbb{T} .

These generating functions go under the name Givental's J-function
or, "cohomological Vertex function" of \mathcal{X} .

The domain curve D



is best thought of an infinite cigar with an S^1 boundary at infinity.

The boundary data is a choice of a K-theory class

$$[\mathcal{F}] \in K_T(\mathcal{X})$$

It determines which solution of the Knizhnik-Zamolodchikov equation

$$\mathcal{V}[\mathcal{F}] = \text{Vertex}[\mathcal{F}]$$

the vertex function computes.

The vertex function is a vector

$$\mathcal{V}_\alpha[\mathcal{F}] = \text{Vertex}_\alpha[\mathcal{F}]$$

due to insertions of classes $\alpha \in H_T^*(\mathcal{X})$ at the origin of D.



Geometric Satake correspondence,

identifies $H_T^*(\mathcal{X})$ with the weight space

$$(V_1 \otimes \dots \otimes V_n)_\nu$$

The geometric interpretation of conformal blocks of

$$\widehat{L\mathfrak{g}}$$

in terms of

$$\mathcal{X}$$

has more information than the conformal blocks themselves.

Underlying the Gromov-Witten theory of

\mathcal{X}

is a two-dimensional supersymmetric “sigma model”

with \mathcal{X} as a target space.

The sigma model describes all maps

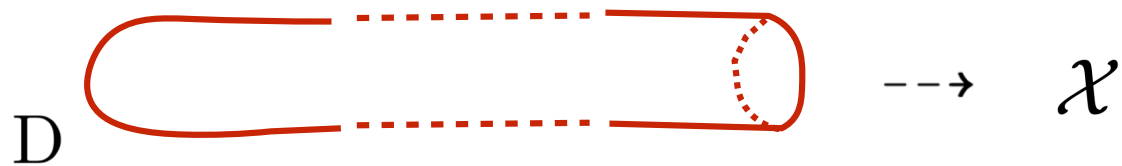

not only holomorphic ones.

The physical meaning of
Gromov-Witten vertex function

$$\mathcal{V}[\mathcal{F}] = \text{Vertex}[\mathcal{F}]$$

is the partition function of the supersymmetric sigma model

with target \mathcal{X} on D



One has, in the interior of D , an A-type twist

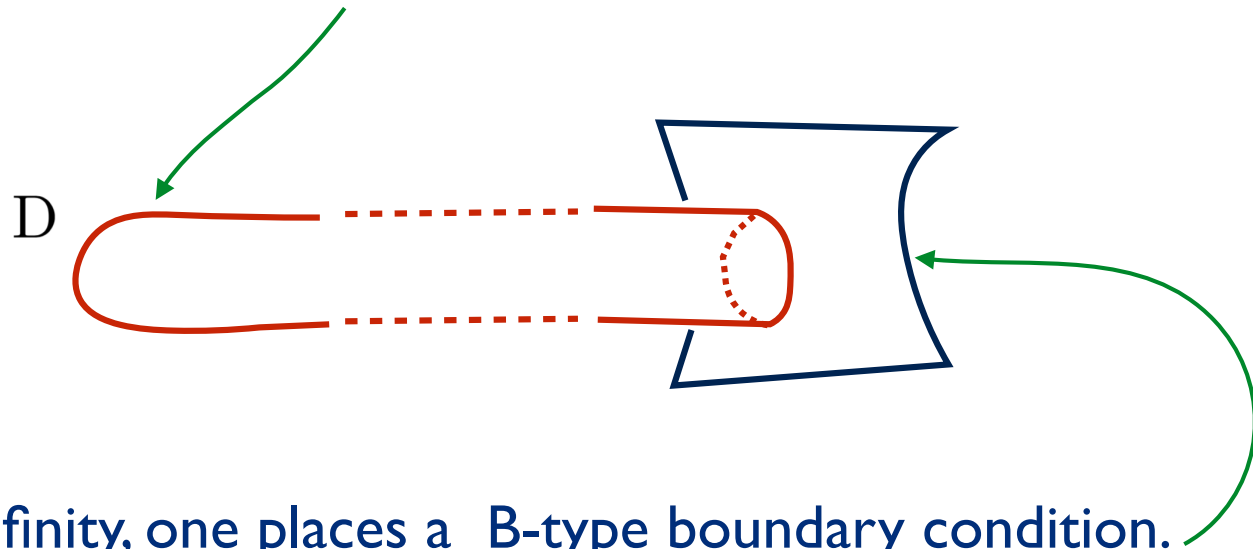

and at infinity, one places a B-type boundary condition.

Boundary conditions form a category, and
the category of boundary conditions of the sigma model on \mathcal{X} ,
preserving a B-type supersymmetry and
working equivariantly with respect to \mathbb{T} is

$$\mathcal{D}_{\mathcal{X}} = D^b \text{Coh}_{\mathbb{T}}(\mathcal{X})$$

the derived category of \mathbb{T} -equivariant coherent sheaves on \mathcal{X}

Picking, as a boundary condition, an object

$$\mathcal{F} \in D^b \text{Coh}_{\mathbb{T}}(\mathcal{X})$$

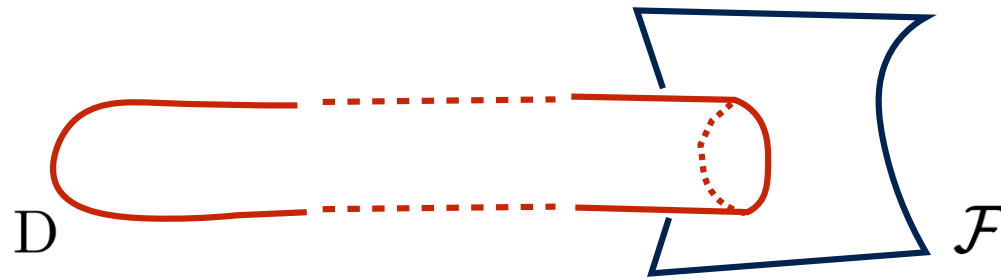

we get $\mathcal{V}[\mathcal{F}] = \text{Vertex}[\mathcal{F}]$ as the partition function.

It depends on the choice of the brane \mathcal{F}

only through its K-theory class

$$[\mathcal{F}] \in K_{\mathbb{T}}(\mathcal{X})$$

Since the Knizhnik-Zamolodchikov equation of

$$\widehat{L\mathfrak{g}}$$

is the quantum differential equation of \mathcal{X} ,

the action of $U_q(L\mathfrak{g})$ on the space of conformal blocks

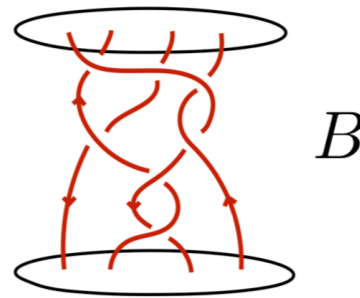

is the monodromy of the quantum differential equation of \mathcal{X} ,

along the path in its Kahler moduli corresponding to the braid.

The action of monodromy

a-priori comes from the action on the K-theory class

$$[\mathcal{F}] \in K_T(\mathcal{X})$$

of the brane at the boundary at infinity

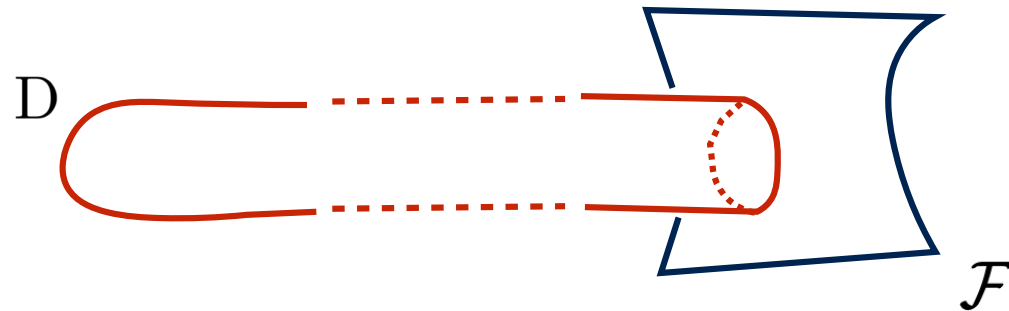

so the $U_q({}^L\mathfrak{g})$ quantum group acts on equivariant K-theory

$$\mathfrak{B} : K_T(\mathcal{X}) \rightarrow K_T(\mathcal{X})$$

Since the sigma model needs the actual brane

$$\mathcal{F} \in D^b \text{Coh}_{\mathbb{T}}(\mathcal{X})$$

to serve as the boundary condition,

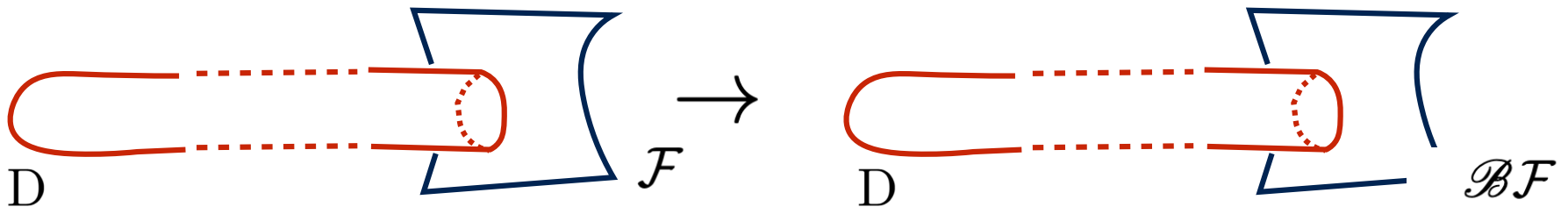

the action of monodromy has to come from

an action on the brane itself,

$$\mathcal{F} \rightarrow \mathcal{BF}$$

Along a path in Kahler moduli

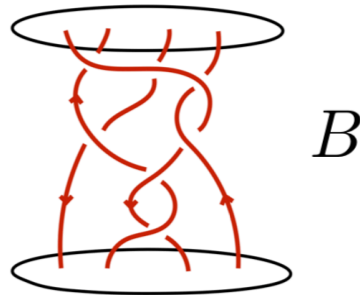

the derived category stays the same, so the braid group
that acts on branes by

$$\mathcal{F} \rightarrow \mathcal{B}\mathcal{F}$$

is an auto-equivalence of the derived category,

$$\mathcal{B} : D^b \text{Coh}_{\mathbb{T}}(\mathcal{X}) \rightarrow D^b \text{Coh}_{\mathbb{T}}(\mathcal{X})$$

From sigma model perspective, the monodromy problem arises

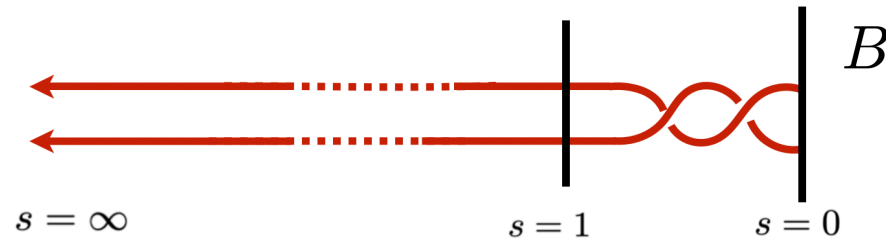

by letting the moduli of the theory vary

according to the braid, in the neighborhood of the boundary at infinity.

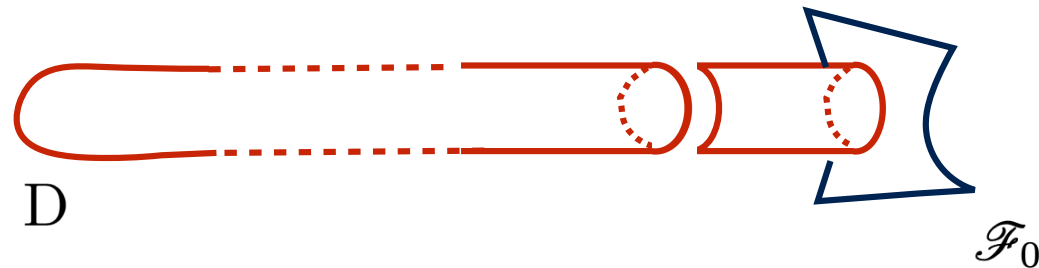

The direction along the cigar coincides with the “time s ” along the braid.

By asking how monodromy

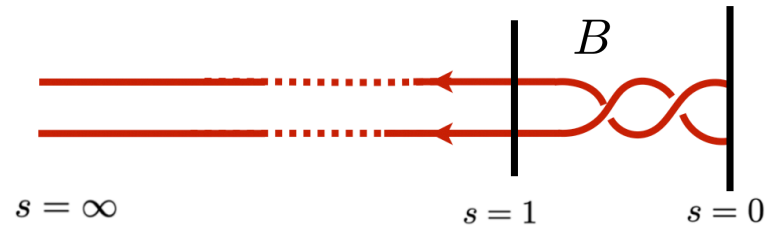

acts on the quantum state produced at $s = 1$

by the path integral over the cigar,

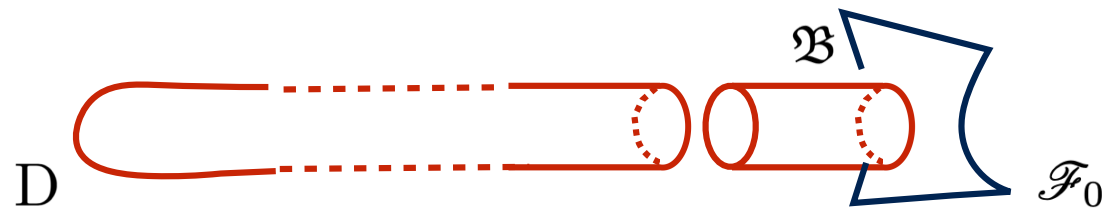

one gets a Berry phase type problem

studied twenty years ago by Cecotti and Vafa.

The solution of the problem is the linear map

$$\mathfrak{B} : K_{\text{T}}(\mathcal{X}) \rightarrow K_{\text{T}}(\mathcal{X})$$

the monodromy of the quantum differential equation,

which acts on the K-theory class of the brane

$$[\mathcal{F}_0] \rightarrow \mathfrak{B}[\mathcal{F}_0]$$

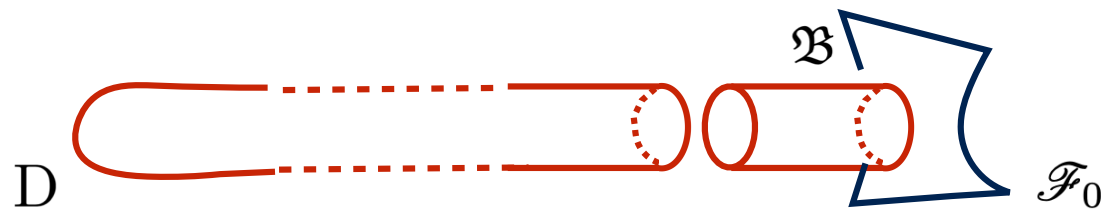

The path integral depends only on the homotopy type of path B

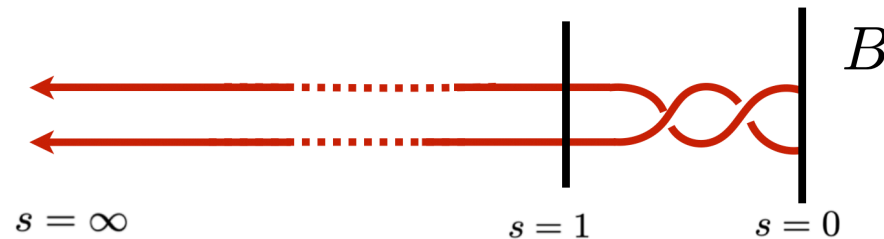

so taking all the variation to happen near the boundary,
we get to keep the moduli constant over the entire cigar,

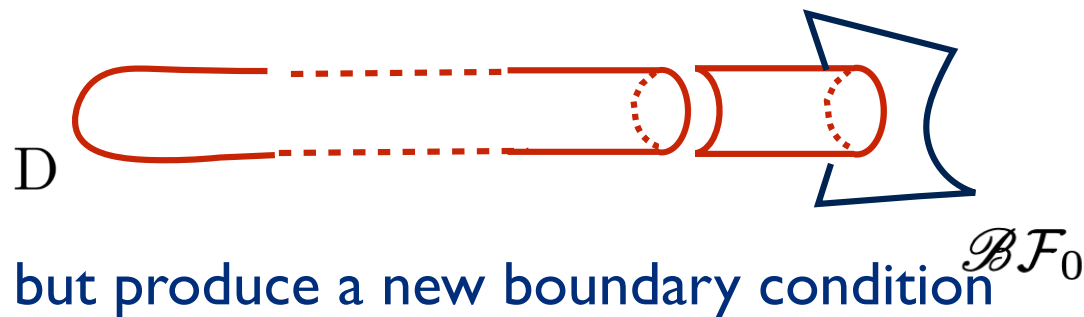

but produce a new boundary condition \mathcal{BF}_0

$$\mathcal{BF}_0 \in \mathcal{D}_X$$

which is the image of \mathcal{F}_0 under the derived equivalence functor \mathcal{B} .

Consistency of these two descriptions

$$[\mathcal{B}\mathcal{F}_0] = \mathfrak{B}[\mathcal{F}_0]$$

says that

the action of braiding on equivariant K-theory

$$\mathfrak{B} : K_{\mathbb{T}}(\mathcal{X}) \rightarrow K_{\mathbb{T}}(\mathcal{X})$$

via the monodromy of the quantum differential equation

lifts to

a derived auto-equivalence functor of the category

$$\mathcal{B} : D^b\text{Coh}_{\mathbb{T}}(\mathcal{X}) \rightarrow D^b\text{Coh}_{\mathbb{T}}(\mathcal{X})$$

This reproduces a very difficult to prove theorem by

Bezrukavnikov and Okounkov.

To extract the monodromy matrix elements

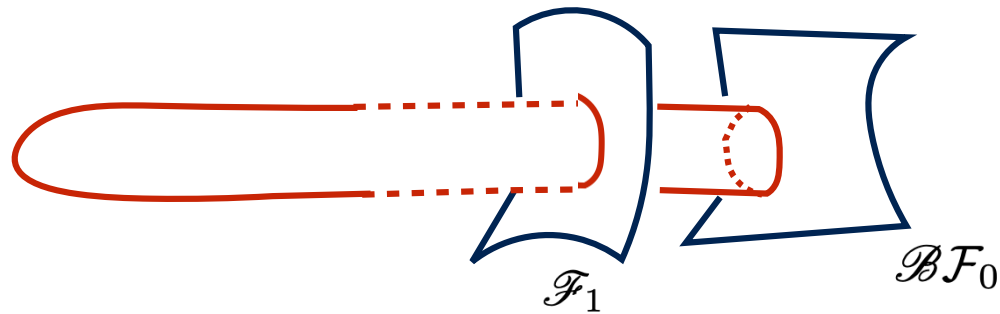

cut the infinite cigar near its boundary, at $s = 1$

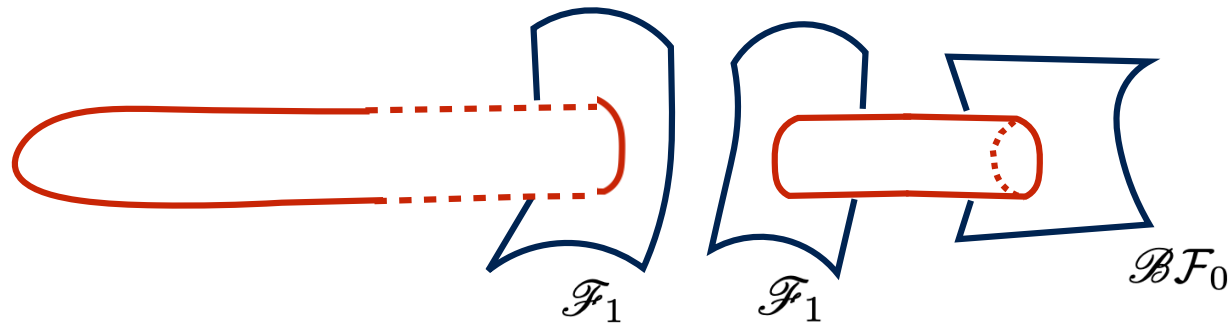

and insert a “complete set of branes”.

Path integral of the sigma model
with the pair of B-branes at the boundary
where **time runs along the annulus**

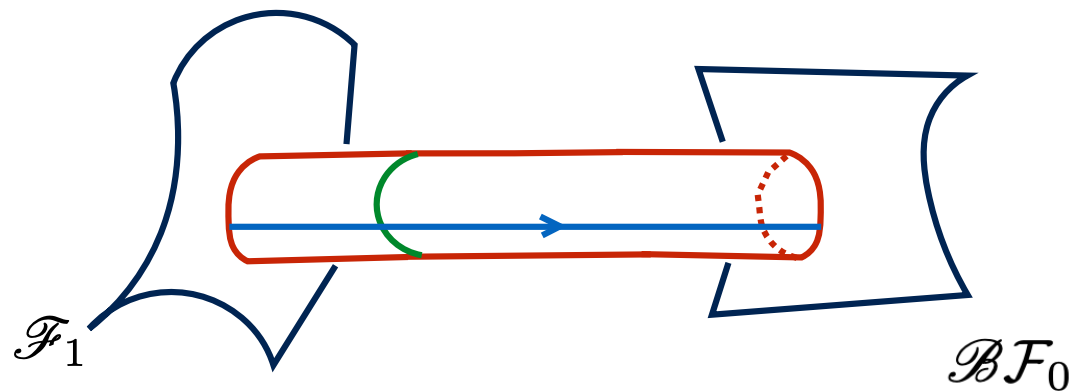

computes the **monodromy matrix element**

$$(\mathcal{V}_1, \mathcal{B}\mathcal{V}_0)$$

where

$$\mathcal{V}_1 = \mathcal{V}[\mathcal{F}_1] \quad \text{and} \quad \mathcal{V}_0 = \mathcal{V}[\mathcal{F}_0]$$

are the vertex functions of the branes.

The same path integral
with time that runs around the S^1 ,

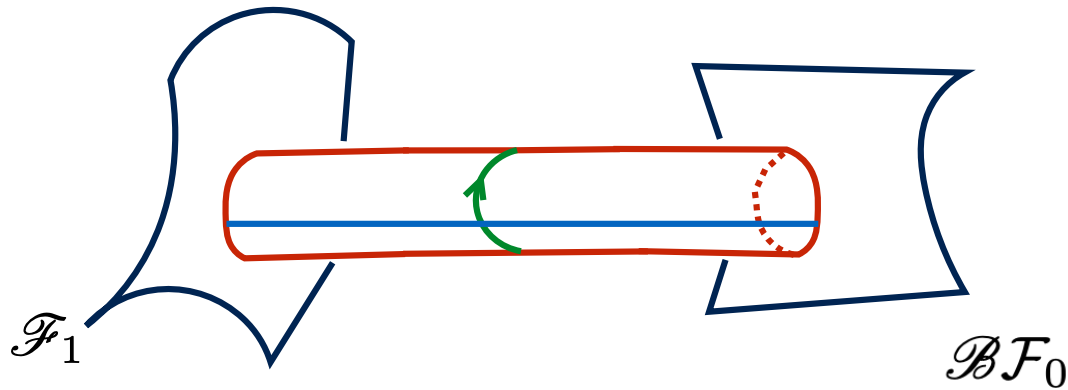

computes the index of the supercharge Q preserved by the two branes.

The cohomology of the supercharge Q

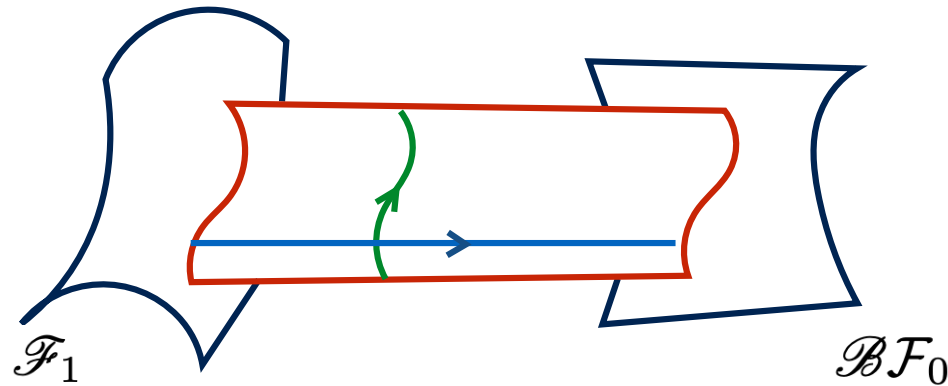

is per definition the graded Hom space between the branes

$$\text{Hom}^{*,*}(\mathcal{F}_1, \mathcal{BF}_0)$$

computed in

$$\mathcal{D}_{\mathcal{X}} = D^b \text{Coh}_{\Gamma}(\mathcal{X})$$

So far, we understood that

$$\mathcal{D}_{\mathcal{X}} = D^b \text{Coh}_{\mathbb{T}}(\mathcal{X})$$

manifestly categorifies

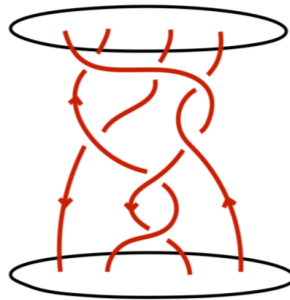

$$\mathfrak{B} \in U_q({}^L \mathfrak{g})$$

braiding matrix elements.

The quantum invariants of links should also be categorized by

$$\mathcal{D}_{\mathcal{X}} = D^b \text{Coh}_{\mathbb{T}}(\mathcal{X})$$

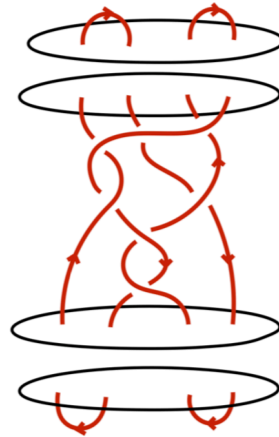

since they too can be expressed as matrix elements of the braiding matrix

$$(\mathcal{U}_1, \mathfrak{B} \mathcal{U}_0)$$

between pairs of conformal blocks.

For this one first needs to understand which branes in

$$\mathcal{D}_{\mathcal{X}} = D^b \text{Coh}_{\mathbb{T}}(\mathcal{X})$$

correspond to conformal blocks



where pairs of vertex operators fuse to trivial representations.

In looking for objects of

$$\mathcal{D}_{\mathcal{X}} = D^b \text{Coh}_{\mathbb{T}}(\mathcal{X})$$

whose vertex functions are conformal blocks

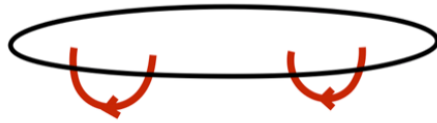

we will discover that not only braiding,
but also fusion has a geometric interpretation in terms of

$$\mathcal{D}_{\mathcal{X}} = D^b \text{Coh}_{\mathbb{T}}(\mathcal{X})$$

For this, we need an additional important insight
contained in the sigma model.

In general, one may have more than one braid group action on the derived category.

The sigma model origin of our theory spells out exactly which derived equivalence functor we are getting.

By its origin in the sigma model to \mathcal{X} , the functor

$$\mathcal{B} : D^b \text{Coh}_{\mathbb{T}}(\mathcal{X}) \rightarrow D^b \text{Coh}_{\mathbb{T}}(\mathcal{X})$$

comes from variation of stability condition on

$$\mathcal{D}_{\mathcal{X}} = D^b \text{Coh}_{\mathbb{T}}(\mathcal{X})$$

defined with respect to a central charge function

$$\mathcal{Z}^0[\mathcal{F}] : K(\mathcal{X}) \rightarrow \mathbb{C}$$

which is a close cousin of $\mathcal{V}[\mathcal{F}]$

The vertex function

$$\mathcal{V}[\mathcal{F}]$$

generalizes the central charge function

$$\mathcal{Z}^0[\mathcal{F}]$$

in two different ways.

Firstly, the vertex function is a vector

$$\mathcal{V}_\alpha[\mathcal{F}] = \text{Vertex}_\alpha[\mathcal{F}]$$

due to insertions of $\alpha \in H_T^*(\mathcal{X})$ classes at the origin of D .

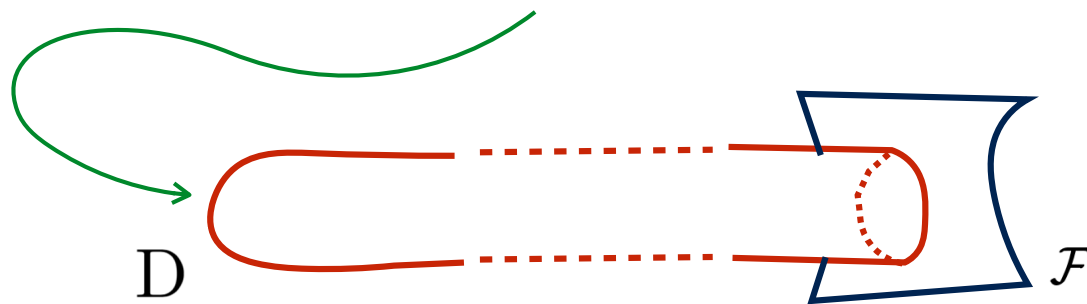

and secondly it depends on equivariant parameters

of the T -action on \mathcal{X} .

Undoing the first generalization, by placing no insertion at the origin
we get a scalar analog of the vertex function

$$\mathcal{Z}[\mathcal{F}] := \text{Vertex}_0[\mathcal{F}]$$

which is the “equivariant central charge function”

$$\mathcal{Z}[\mathcal{F}] : K_{\text{T}}(\mathcal{X}) \rightarrow \mathbb{C}$$



The central charge function that provides the stability condition on the category

$$\mathcal{Z}^0[\mathcal{F}] : K(\mathcal{X}) \rightarrow \mathbb{C}$$

is obtained from the equivariant central charge by

$$\mathcal{Z}[\mathcal{F}] : K_T(\mathcal{X}) \rightarrow \mathbb{C}$$

setting the T-equivariant parameters to zero.

The stability condition defined with respect to

$$Z^0[\mathcal{F}] : K(\mathcal{X}) \rightarrow \mathbb{C}$$

is known as the Pi stability condition,
discovered by Douglas.

Our setting should be a source of model examples of
a Bridgeland stability conditions.

In fact, the original reason why physicists
were interested in understanding vertex functions,
is because they compute
(generalized) central charges.

Now we can return to understanding how

$$\mathcal{D}_{\mathcal{X}} = D^b \text{Coh}_{\mathbb{T}}(\mathcal{X})$$

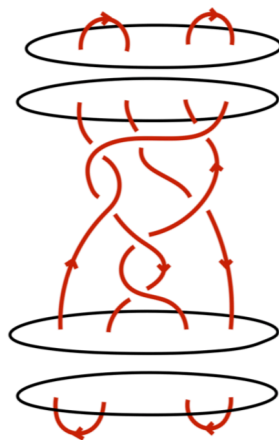

categories $U_{\mathfrak{q}}({}^L \mathfrak{g})$ invariants of links.

One of the lessons from the very early days of mirror symmetry is that the geometry of \mathcal{X} near a point in its moduli space where it develops a singularity is reflected in the behavior of its central charges.

For us, the central charges are close cousins of conformal blocks,
so the behavior of conformal blocks
must be reflected in the geometry of \mathcal{X} .

As a pair of vertex operators
approach, one gets a natural basis of conformal blocks
obtained by
sewing chiral vertex operators as follows:



the “fusion basis”.

Possible choices of fusion products

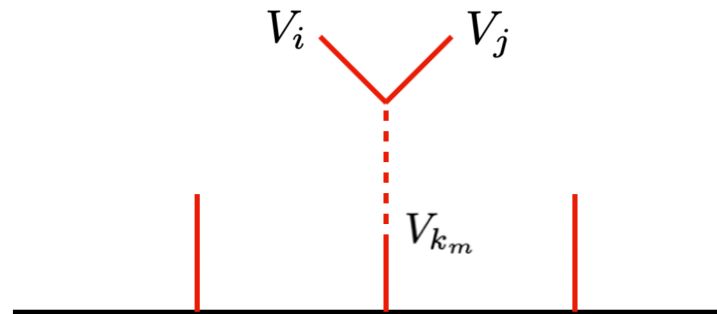

are labeled by representations

$$V_i \otimes V_j = \bigoplus_{m=0}^{m_{max}} V_{k_m}$$

that occur in the tensor product.

A basic result in conformal field theory is that

“fusion diagonalizes braiding”

In the fusion basis, braiding acts diagonally,

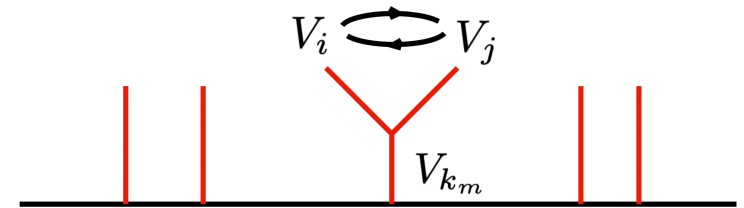
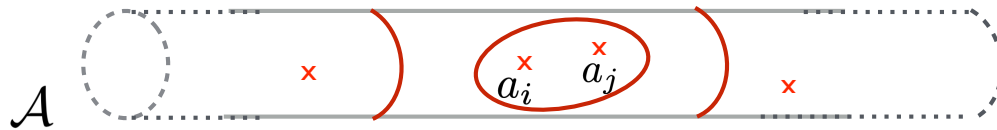

unlike in the basis we started the talk with

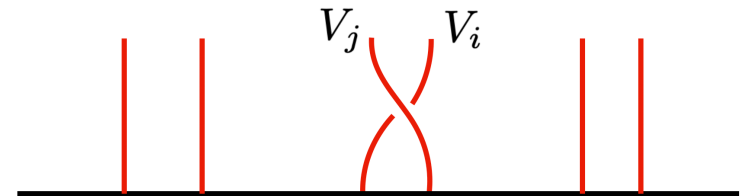
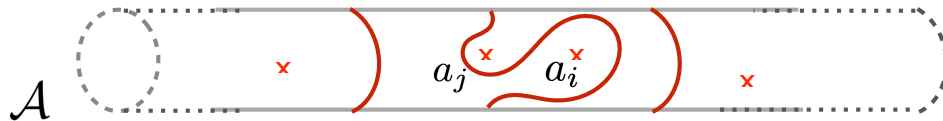

Corresponding to a pair of vertex operators coming together

$$a_i \rightarrow a_j$$

is a limit in Kahler moduli of

$$\mathcal{X} = \text{Gr}^{\vec{\mu}}_{\nu}$$

in which it develops a singularity due to a collection of vanishing cycles

$$F_{k_m}$$

labeled by representations in the tensor product

$$V_i \otimes V_j = \bigotimes_{m=0}^{m_{max}} V_{k_m}$$

These vanishing cycles give rise to objects of the derived category

$$\mathcal{F}_{k_m} \in \mathcal{D}\mathcal{X}$$

whose vertex functions have the same leading behavior near

the singularity at

$$a_i \rightarrow a_j$$

as the conformal blocks in the fusion basis.

Conformal blocks which diagonalize the action of braiding
do not in general come from actual objects
of the derived category $\mathcal{D}_{\mathcal{X}} = D^b \text{Coh}_{\mathbb{T}}(\mathcal{X})$.

Eigensheaves of braiding $\mathcal{E} \subset \mathcal{D}_{\mathcal{X}}$ on which
the braiding functor acts as

$$\mathcal{B}\mathcal{E} = \mathcal{E}[-D_{\mathcal{E}}]\{C_{\mathcal{E}}\}$$

are rare.

What we get instead is a filtration

$$\mathcal{D}_{k_0} \subset \mathcal{D}_{k_1} \dots \subset \mathcal{D}_{k_{max}} = \mathcal{D}_{\mathcal{X}}$$

on the derived category $\mathcal{D}_{\mathcal{X}} = D^b Coh_{\mathbb{T}}(\mathcal{X})$,

with terms in the filtration labeled by distinct representations

$$V_i \otimes V_j = \bigotimes_{m=0}^{m_{max}} V_{k_m}$$

in the tensor product

Branes in the m -th term of the filtration

$$\mathcal{F}_{k_m} \in \mathcal{D}_m$$

come as close as possible to being eigensheaves.

They have central charges that vanish at least as fast as

$$\mathcal{Z}^0[\mathcal{F}_{k_m}] \sim \mathcal{Z}_{k_m}^0 = (a_i - a_j)^{D_m} \times \text{finite}$$

as the dimension of the corresponding vanishing cycle F_{k_m}

$$D_m = \dim_{\mathbb{C}} F_{k_m}$$

but in general contain terms that vanish faster.

The order of vanishing $D_m \geq D_{m+1}$ increases as m decreases.

Braiding which exchanges the pair of vertex operators

$$\Phi_{V_j}(a_j) \otimes \Phi_{V_i}(a_i)$$

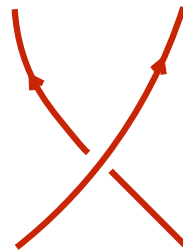

$$\Phi_{V_i}(a_i) \otimes \Phi_{V_j}(a_j)$$

corresponds to a **generalized flop** in the geometry.

The flop is generalized since more than one cycle vanishes,

and in general the vanishing cycles are not spherical.

By analyticity of the central charge function we get a pair of filtrations, one on each side of the flop:

$$\mathcal{D}_{k_0} \subset \mathcal{D}_{k_1} \dots \subset \mathcal{D}_{k_{max}} = \mathcal{D}_{\mathcal{X}}$$

for $|a_i| < |a_j|$ and

$$\mathcal{D}'_{k_0} \subset \mathcal{D}'_{k_1} \dots \subset \mathcal{D}'_{k_{max}} = \mathcal{D}'_{\mathcal{X}}$$

for $|a_j| < |a_i|$.

Braiding preserves the filtrations,

$$\Phi_{V_j}(a_j) \otimes \Phi_{V_i}(a_i)$$

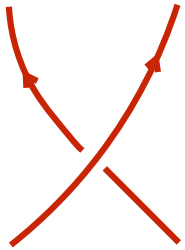

$$\Phi_{V_i}(a_i) \otimes \Phi_{V_j}(a_j)$$

$$\mathcal{D}'_{k_0} \subset \mathcal{D}'_{k_1} \dots \subset \mathcal{D}'_{k_{max}} = \mathcal{D}'_{\mathcal{X}}$$

and

$$\mathcal{D}_{k_0} \subset \mathcal{D}_{k_1} \dots \subset \mathcal{D}_{k_{max}} = \mathcal{D}_{\mathcal{X}}$$

since it has the effect of mixing up objects of a

given order of vanishing of central charge,

with those of that vanish faster, and which belong to lower orders

in the filtration.

The degree shifts $[-D_m]\{C_m\}$ that determine the action of the braiding functor

$$\mathcal{B} : \mathcal{D}_m/\mathcal{D}_{m-1} \rightarrow \mathcal{D}'_m/\mathcal{D}'_{m-1} \cong \mathcal{D}_m/\mathcal{D}_{m-1}[-D_m]\{C_m\}$$

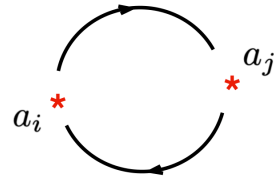

can be read off from the behavior of equivariant central charges,

the scalar cousins of conformal blocks:

$$\mathcal{Z}_{k_m} = (a_i - a_j)^{D_m - C_m/\kappa} \times \text{finite.}$$

Here D_m is the dimension of the vanishing cycle and C_m is known.

Thus, existence of these filtrations
is the geometric and categorical origin
of the statement in conformal field theory
that fusion diagonalizes braiding.

Derived equivalences of this type are **perverse equivalences** of
Rouquier and Chuang.

Our theory is a source of examples,
which come from geometry and physics.

We can now characterize branes of

$$\mathcal{D}_{\mathcal{X}} = D^b \text{Coh}_{\mathbb{T}}(\mathcal{X})$$

whose vertex functions are conformal blocks



describing cups and caps.

The cap colored by a representation V_i

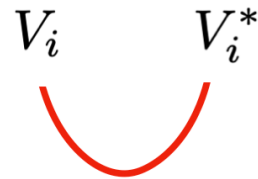

comes from a pair of vertex operators, colored by conjugate representations

$$\Phi_{V_i}(a_i) \otimes \Phi_{V_i^*}(a_j) \rightarrow \mathbb{1}$$

which approach each other and fuse to the identity.

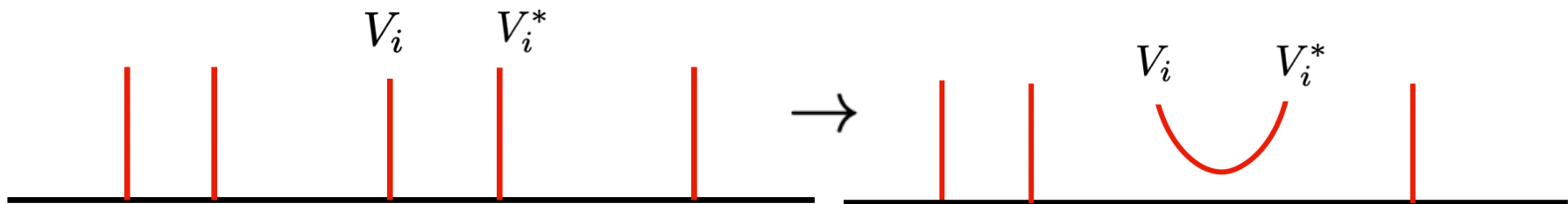

The objects $\mathcal{U} \in \mathcal{D}_{\mathcal{X}}$ corresponding to such conformal blocks

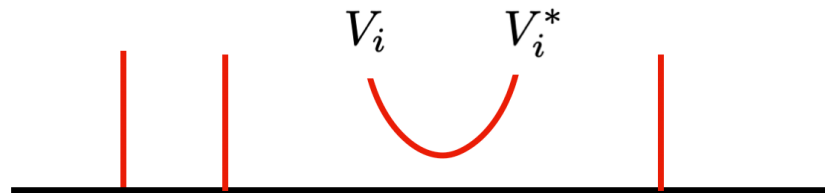

belong to the lowest term of the filtration

$$\mathcal{D}_{k_0} \subset \mathcal{D}_{k_1} \dots \subset \mathcal{D}_{k_{max}} = \mathcal{D}_{\mathcal{X}}$$

corresponding to bringing V_i and V_i^* together

so they are necessarily eigensheaves the braiding functor

$$\mathcal{B}\mathcal{U} = \mathcal{U}[-D_0]\{C_0\}$$

Even then, they are extremely special ones,
for the same reason the identity representation is special.

Associated to identity representation in the tensor product

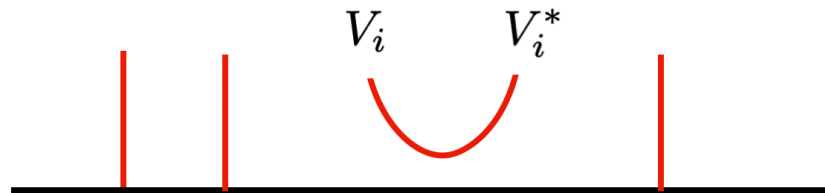

where V_i is a minuscule representation

is a vanishing cycle

known as the minuscule Grassmannian

$$U_i = \text{Gr}^{\mu_i} = G/P_i$$

where P_i is a maximal parabolic subgroup of G

When a collection of vertex operators come together in pairs of minuscule representations and their conjugates

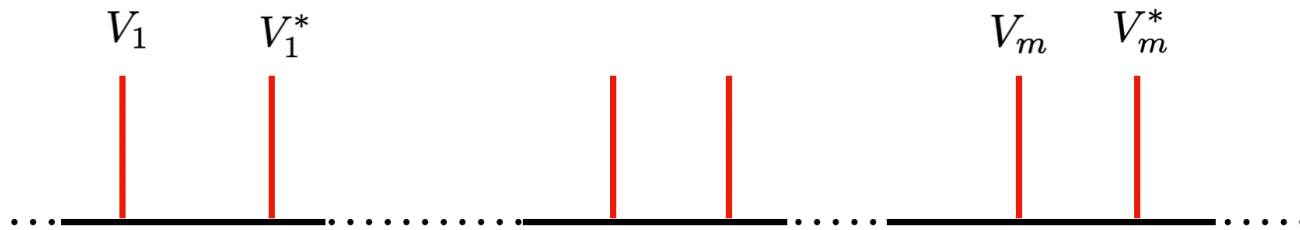

our manifold has a local neighborhood where we can approximate it as

$$\mathcal{X} \sim T^*U$$

where

$$U = U_1 \times \dots \times U_m = G/P_1 \times \dots \times G/P_m$$

is a product of minuscule Grassmannians:

$$U_i = \text{Gr}^{\mu_i} = G/P_i$$

We get a very special B-type brane

$$\mathcal{U} \in \mathcal{D}\mathcal{X}$$

which is the structure sheaf of this vanishing cycle,

$$\mathcal{U} = \mathcal{O}_U$$

Among other things, the vertex function of this brane is the conformal block

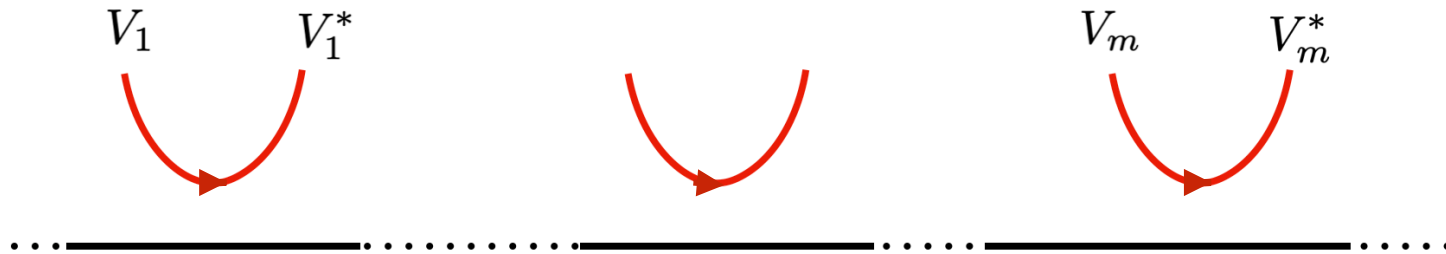

which we will denote by

$$\mathfrak{U} = \mathcal{V}[\mathcal{U}]$$

For these branes,

$$\text{Hom}^{*,*}(\mathcal{U}, \mathcal{B}\mathcal{U})$$

are automatically **braid invariants** whose Euler characteristic

$$\chi(\mathcal{U}, \mathcal{B}\mathcal{U}) = \sum_{n,k \in \mathbb{Z}} (-1)^n q^{k-D/2} \dim \text{Hom}(\mathcal{U}, \mathcal{B}\mathcal{U}[n]\{k\})$$

is the matrix element

$$\chi(\mathcal{U}, \mathcal{B}\mathcal{U}) = (\mathcal{U}, \mathcal{B}\mathcal{U})$$

of the corresponding braiding matrix $\mathcal{B} \in U_q({}^L\mathfrak{g})$

Using very special properties of these branes one can show that,
moreover, not only do the homology groups

$$\text{Hom}^{*,*}(\mathcal{U}, \mathcal{BU})$$

categorify the corresponding $U_q(L\mathfrak{g})$ link invariant,

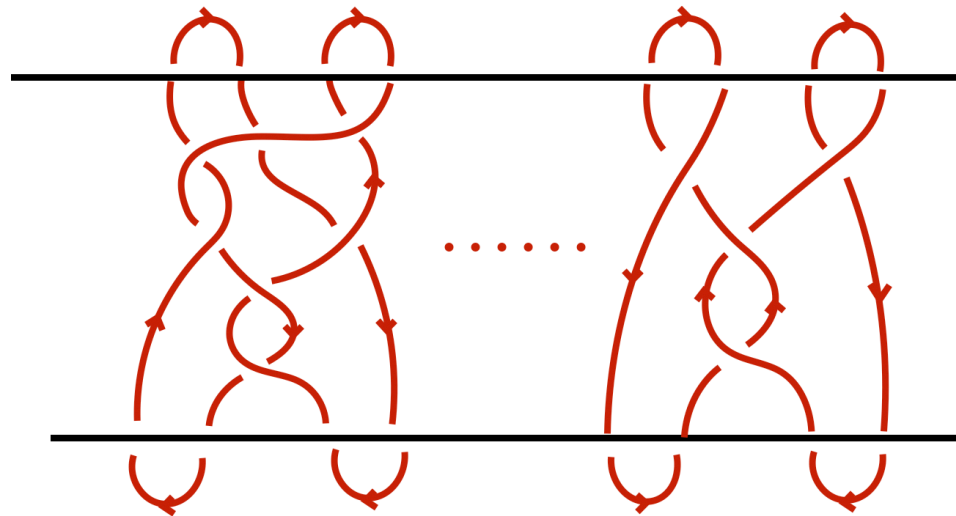

they are themselves link invariants.

An elementary consequence of this approach
is a geometric explanation for
mirror symmetry of $U_{\mathfrak{q}}({}^L\mathfrak{g})$ link invariants
which states that the invariants of
a link K and its mirror image K^*
are related by

$$\mathcal{J}_K(\mathfrak{q}) = \mathcal{J}_{K^*}(\mathfrak{q}^{-1})$$

In this approach mirror symmetry of links follows from Serre duality

$$\text{Hom}_{\mathcal{D}_X}(\mathcal{F}, \mathcal{G}[n]\{k\}) = \text{Hom}_{\mathcal{D}_X}(\mathcal{G}, \mathcal{F}[2D - n]\{D - k\})$$

which is an isomorphism of Q -cohomology

with branes \mathcal{F} and \mathcal{G} at the two ends

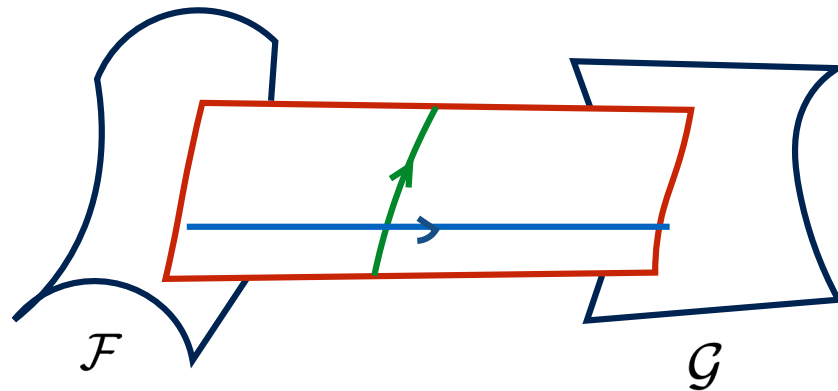

and Q -cohomology obtained by a reflection that exchanges the endpoints.

The shift in the equivariant degree comes from the fact that, while K_X

is trivial, its unique holomorphic section is not invariant under \mathbb{C}_q^\times .

Starting with Serre duality,

$$\mathrm{Hom}_{\mathcal{D}_x}(\mathcal{U}, \mathcal{BU}[n]\{k\}) = \mathrm{Hom}_{\mathcal{D}_x}(\mathcal{BU}, \mathcal{U}[2D - n]\{D - k\})$$

taking the Euler characteristic of both sides

$$\chi(\mathcal{F}, \mathcal{G}) = \sum_{n \in \mathbb{Z}, k \in \mathbb{Z}^{\mathrm{rk}T}} (-1)^n \mathbf{q}^{k - D/2} \dim \mathrm{Hom}_{\mathcal{D}_x}(\mathcal{F}, \mathcal{G}[n]\{k\})$$

and using

$$\chi(\mathcal{U}, \mathcal{BU})(\mathbf{q}) = J_K(\mathbf{q}) \quad \chi(\mathcal{BU}, \mathcal{U})(\mathbf{q}) = J_{K^*}(\mathbf{q})$$

one finds

$$\mathcal{J}_K(\mathbf{q}) = \mathcal{J}_{K^*}(\mathbf{q}^{-1})$$

While new, the fact that Serre duality implies mirror symmetry

$$\mathcal{J}_K(\mathfrak{q}) = \mathcal{J}_{K^*}(\mathfrak{q}^{-1})$$

is not an accident, since the directions along the interval

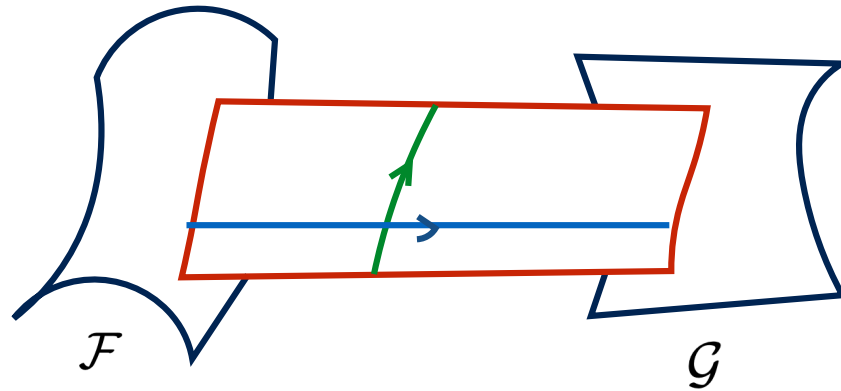

and along the link, which get reflected, coincide.

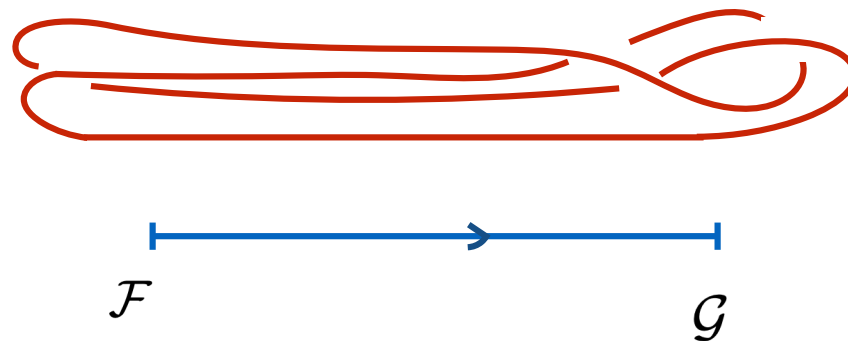

Mirror symmetry
gives a second description of homological
knot invariants.

It is based on the "equivariant mirror" of

\mathcal{X}

The equivariant mirror
is a Landau-Ginzburg theory with target Y ,
and potential W_{LG} .

Ordinary, non-equivariant mirror of

$$\mathcal{X}$$

is a hyper-Kähler manifold

$$\mathcal{Y}$$

which is, to a first approximation,

given by a hyper-Kähler rotation of \mathcal{X}

As \mathcal{X} has only Kahler but not complex moduli,
due to the \mathbb{T} -equivariance we impose,

\mathcal{Y} has only complex but no Kahler moduli turned on.

A description based on

\mathcal{Y}

would give a symplectic geometry approach to the categorification problem,

with

$$\mathcal{D}_{\mathcal{X}} = D^b \text{Coh}_{\mathbb{T}}(\mathcal{X})$$

replaced by its homological mirror, an appropriate category of

Lagrangian branes on \mathcal{Y}

At the moment, one only knows how to obtain from

\mathcal{Y}

“symplectic” homological link invariants,

which only capture the theory at

$$q = 1$$

such as those in the works of Seidel and Smith, for Khovanov homology.

There is an alternative symplectic geometry approach,
where the dependence of the theory
on $\mathfrak{q} = e^{2\pi i\beta}$
instead of being mysterious,
is manifest.

The key fact is that, since we work equivariantly with respect to the

$$\mathbb{C}_q^\times \subset T$$

action on \mathcal{X} , which scales the holomorphic symplectic form

all the relevant information about its geometry

is contained in its fixed locus,

$$X = \mathcal{X}|_{\mathbb{C}_q^\times}$$

which is a holomorphic Lagrangian, its “core”.

Viewing \mathcal{X} as the moduli space of monopoles on

$$\mathbb{R}^3 = \mathbb{R} \times \mathbb{C}$$

its core X is a locus in the moduli space where all the monopoles, singular or not, are at the origin of \mathbb{C} and at points in \mathbb{R}

Instead of working with \mathcal{X} and its mirror \mathcal{Y}
 one can work with the the core X and the core's mirror Y

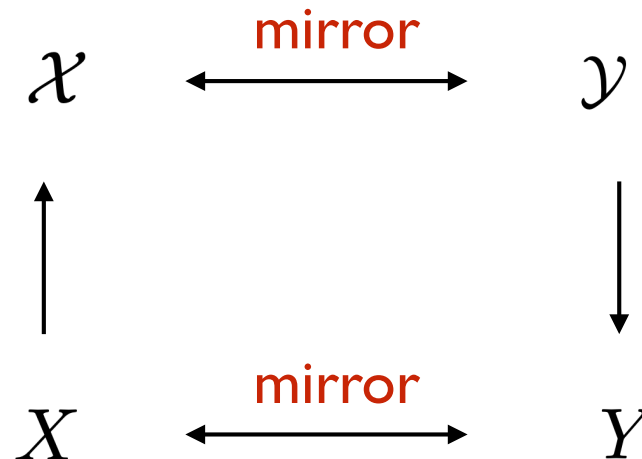

Working equivariantly with respect to $\mathbb{C}_q^\times \subset T$ action on \mathcal{X} ,

the bottom row has as much information about the geometry

as the top.

While X embeds into \mathcal{X} as a
holomorphic Lagrangian submanifold of dimension n
 \mathcal{Y} fibers over Y with holomorphic Lagrangian $(\mathbb{C}^\times)^n$ fibers

For example, for

\mathcal{X} which is an A_n surface, its core X looks like

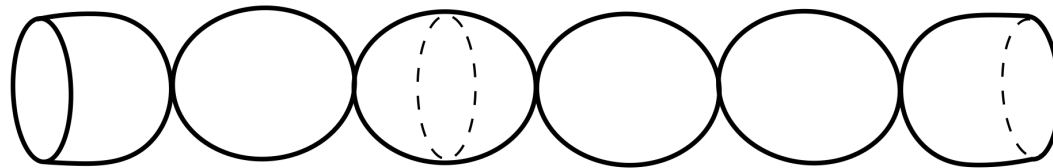

and its mirror \mathcal{Y} is a \mathbb{C}^\times fibration over Y , which looks like

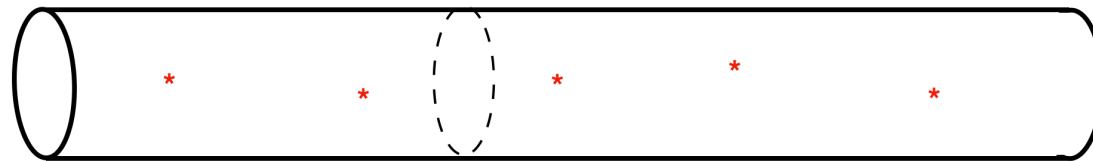

and is mirror to X .

In this case, Y is a single copy of the surface A from the beginning of the talk, with marked points where the \mathbb{C}^\times fibration degenerates.

Mirror to vanishing \mathbb{P}^1 's in X

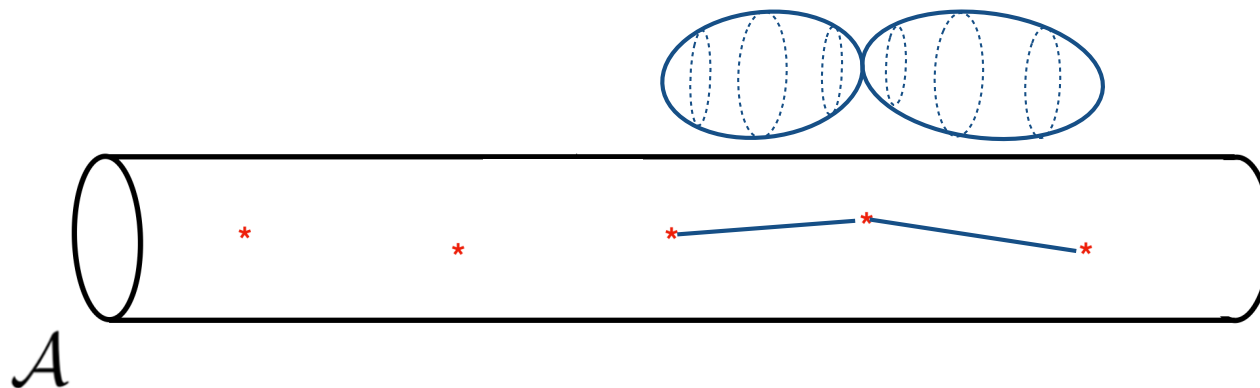

are Lagrangians in Y that begin and end at the punctures, and which are projections from Lagrangian spheres in \mathcal{Y} .

More generally, the equivariant mirror of

$$\mathcal{X} = Gr^{\vec{\mu}}_{\nu}$$

and the ordinary mirror of its core X , is

$$Y = (\mathcal{A})^{D,*} / \text{Weyl}$$

where D is the total number of smooth monopoles



and \mathcal{A} is our Riemann surface.

Projecting to the common SYZ base of

X and of Y

is the same as projecting \mathcal{X} ,

the moduli space of singular monopoles on

$$\mathbb{R}^3 = \mathbb{R} \times \mathbb{C}$$

to



Including an equivariant T -action

on \mathcal{X} and on X

corresponds to adding to the sigma model on

$$Y = (\mathcal{A})^{D,*} / \text{Weyl}$$

a specific potential,

$$W_{LG}$$

which is a multi-valued holomorphic function on Y .

The potential W_{LG} is a multi-valued holomorphic function on Y , which is a sum of three types of terms, all coming from the equivariant actions

a term coming from the $\Lambda \subset \mathbb{T}$ -action:

$$W_1 = \sum_a \sum_{\alpha} \ln(x_{\alpha,a})^{(Le_a, \lambda)}$$

and two which come from the $\mathbb{C}_q^{\times} \subset \mathbb{T}$ action:

$$W_2 = \sum_a \sum_{\alpha, i} \ln(x_{\alpha,a} - a_i)^{-(Le_a, \mu_i)/\kappa}, \quad W_3 = \sum_{a,b} \sum_{\alpha < \beta} \ln(x_{\alpha,a} - x_{\beta,b})^{-(Le_a, Le_b)/\kappa}$$

Mirror symmetry predicts that conformal blocks of $\widehat{L\mathfrak{g}}$

$$\langle \lambda | \Phi_{L\rho_1}(a_1) \cdots \Phi_{L\rho_n}(a_n) | \lambda' \rangle$$

are partition functions of the B-twisted theory on D ,

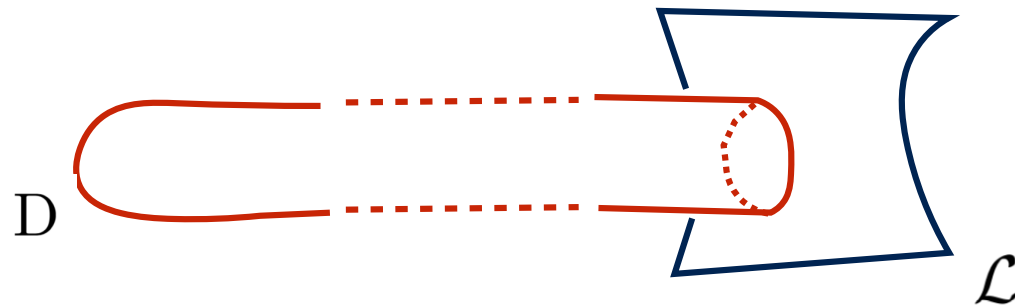

with an A-type boundary conditions at infinity, corresponding to a Lagrangian \mathcal{L} in Y .

Such amplitudes have the following form

$$\int_L \Phi_a \Omega e^{W_{LG}}$$

where Ω is the top holomorphic form on Y ,

$$W_{LG}$$

is the Landau-Ginsburg potential,

and Φ 's are the chiral ring operators.

We are rediscovering here, from mirror symmetry,
the integral formulation of the $\widehat{L\mathfrak{g}}$ conformal blocks

$$\langle \lambda | \Phi_{L\rho_1}(a_1) \cdots \Phi_{L\rho_n}(a_n) | \lambda' \rangle$$

which goes back to work of Feigin and E.Frenkel in the '80's
and Schechtman and Varchenko.

There is a reconstruction theory,
due to Givental and Teleman,
which says that starting with the genus zero data,
or more precisely, with the solution of quantum differential equation,
one gets to reconstruct all genus topological string amplitudes
of a semi-simple 2d field theory.

Thus, the B-twisted the Landau-Ginsburg model (Y, W_{LG})
and A-twisted sigma model on \mathcal{X} ,
working equivariantly with respect to T ,
are expected to be equivalent to all genus.

Corresponding to a solution of the
 Knizhnik-Zamolodchikov equation
 is an A-brane at the boundary of \mathcal{D} at infinity,

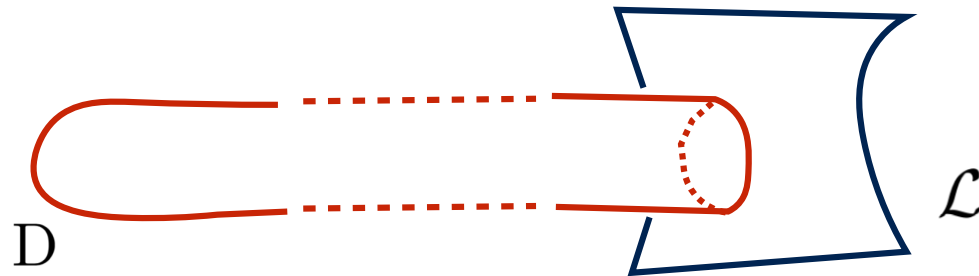

The brane is an object of

$$\mathcal{D}_Y = D(\mathcal{FS}(Y, W_{LG}))$$

the derived Fukaya-Seidel category of A-branes on Y with potential W_{LG}

The objects of $\mathcal{D}_Y = D(\mathcal{FS}(Y, W_{LG}))$ are graded Lagrangians

$$\tilde{L} \in \mathcal{D}_Y$$

where the grading is the Maslov grading,
together with additional grades which come from
the non-single valued potential.

The additional grades may be defined
by lifting the phase of

$$\Omega e^{W_{LG}}$$

to a real valued function on the Lagrangian,
analogously to the way the lift of the phase of

$$\Omega$$

is used used to define the cohomological, Maslov grading.

In general, to formulate a category of
A-branes on a non-compact manifold such as
 Y
requires work, to cure the non-compactness.

In the present case, we are after a symplectic-geometry based approach to knot homology.

The Lagrangians we need are all compact, since they are related by mirror symmetry to compact vanishing cycles on \mathcal{X} .

For such Lagrangians,
there are no issues with non-compactness of Y
The superpotential W_{LG} would have played no role either,
were it single valued.

W_{LG} is not single valued for us,

but its main effect is to provide additional gradings on

$$HF^{*,*}(L_{out}, L_{in}) = \bigoplus_{n \in \mathbb{Z}, k \in \mathbb{Z}^{\text{rk}T}} \text{Hom}_{\mathcal{D}_Y}(L_{out}, L_{in}[n]\{k\})$$

the Floer cohomology groups.

Mirror symmetry

helps us understand exactly which questions we need to ask

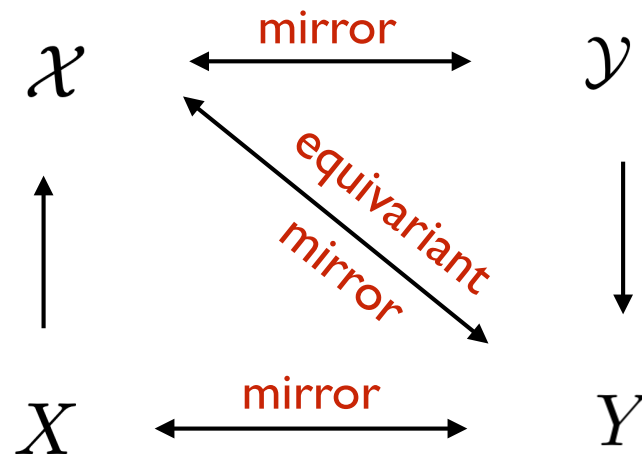

to recover homological knot invariants from Y .

Since Y is an ordinary mirror of X ,
we should start by understanding how to recover

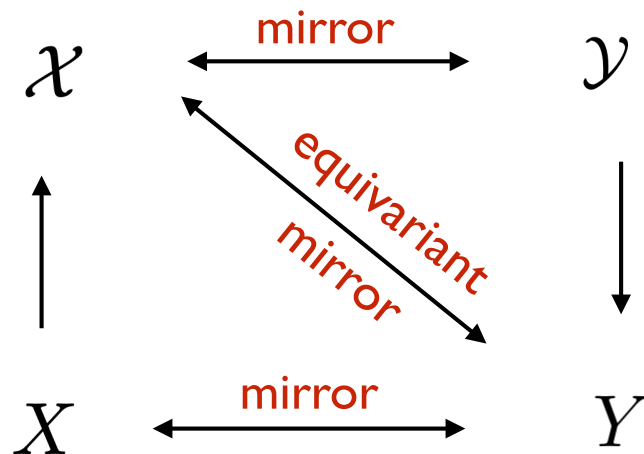

homological knot invariants from X , instead of \mathcal{X}

Every B-brane on \mathcal{X} which is relevant to us

“comes from” a B-brane on X

via a pushforward functor,

$$f_* : \mathcal{D}_X \rightarrow \mathcal{D}_{\mathcal{X}}$$

that interprets a sheaf F on X , (more precisely, an object of \mathcal{D}_X)

as a sheaf $\mathcal{F} = f_* F$ on \mathcal{X}

This functor has an adjoint, that goes the other way,

$$f^* : \mathcal{D}_{\mathcal{X}} \rightarrow \mathcal{D}_X$$

that takes a sheaf on \mathcal{X} to a sheaf on X ,

by tensoring with the structure sheaf \mathcal{O}_X , and restricting to X

The fact these are adjoint functors is what lets us relate the computations of

Hom's on \mathcal{X} to those on X .

Given any pair of objects on \mathcal{X} that come from X
the Hom between them, computed upstairs, in $\mathcal{D}_{\mathcal{X}}$

$$\mathcal{F} = f_*F, \quad \mathcal{G} = f_*G$$

agrees with the Hom downstairs, in \mathcal{D}_X ,

$$Hom_{\mathcal{D}_{\mathcal{X}}}^{*,*}(\mathcal{F}, \mathcal{G}) = Hom_{\mathcal{D}_X}^{*,*}(f^*f_*F, G)$$

after replacing F with f^*f_*F

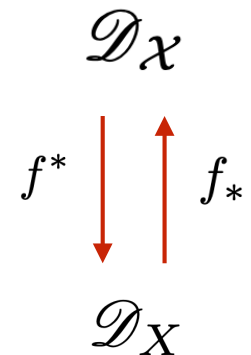

By mirror symmetry, for every pair of objects

$$\mathcal{F} = f_*F, \quad \mathcal{G} = f_*G$$

on \mathcal{X} which come from X , there has to be a pair of Lagrangians

$$L_F, \quad L_G$$

on Y which are mirror to F and G ,

$$\mathrm{Hom}_{\mathcal{D}_{\mathcal{X}}}(\mathcal{F}, \mathcal{G}) = \mathrm{Hom}_{\mathcal{D}_{(Y, W)}}(k^*k_*L_F, L_G)$$

such that Hom's on Y agree with those on \mathcal{X} .

The functors k_* and k^* that enter

$$\text{Hom}_{\mathcal{D}_X}(\mathcal{F}, \mathcal{G}) = \text{Hom}_{\mathcal{D}_{(Y,W)}}(k^*k_*L_F, L_G)$$

relate objects on Y and on \mathcal{Y} ,

in a way that mirrors f^* and f_* ,

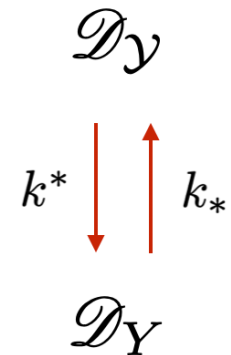

Construction of these functors,

and the parallel understanding of mirror symmetries upstairs and downstairs

is joint work with Shende and McBreen.

Mirror symmetry and these functors

$$\begin{array}{ccc} \mathcal{D}_X & \xleftrightarrow{\text{mirror}} & \mathcal{D}_Y \\ f^* \downarrow \uparrow f_* & \begin{array}{c} \text{equivariant} \\ \text{mirror} \end{array} & k^* \downarrow \uparrow k_* \\ \mathcal{D}_X & \xleftrightarrow{\text{mirror}} & \mathcal{D}_Y \end{array}$$

let us trade any question in the upper left corner
for a question in the lower right,
giving us a definition of
equivariant homological mirror symmetry.

Recall our example, Y the equivariant mirror to
 \mathcal{X} which is the A_n surface.

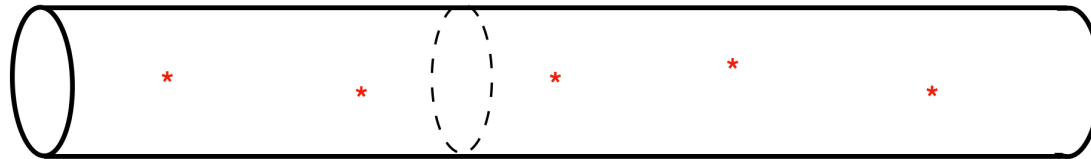

Mirror to i -th vanishing \mathbb{P}^1 in X is the Lagrangian
 L_i in Y .

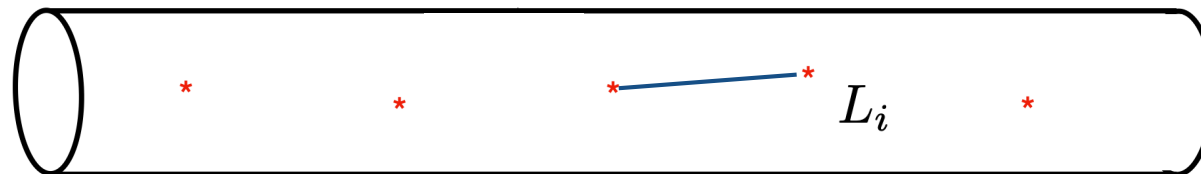

The mirror of \mathcal{X} is \mathcal{Y} the multiplicative A_n surface,
 which is a \mathbb{C}^\times fibration over Y .

The functor $k_* : \mathcal{D}_Y \rightarrow \mathcal{D}_{\mathcal{Y}}$ maps any Lagrangian in Y ,
 to a Lagrangian in \mathcal{Y} , which fibers over Y with S^1 fibers.

In particular, $k_* L_i$ is the i -th vanishing sphere in \mathcal{Y} .

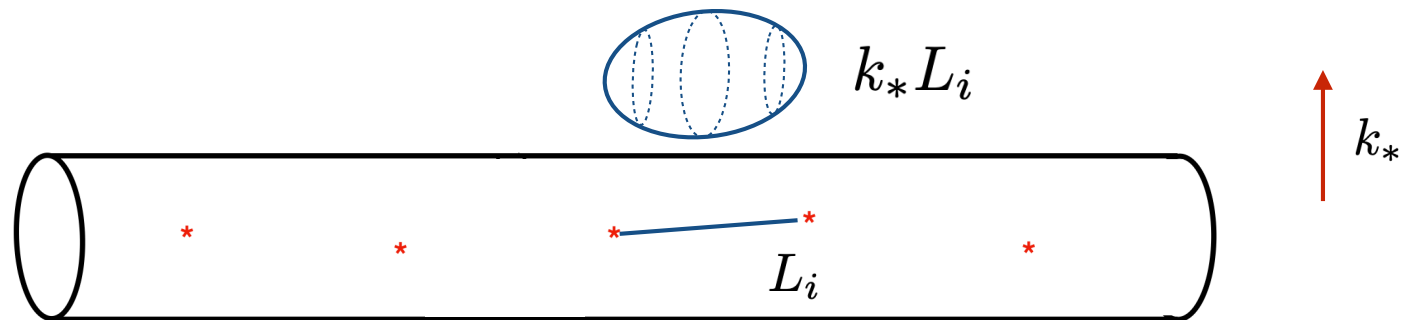

The functor going the other way

$$k^* : \mathcal{D}_Y \rightarrow \mathcal{D}_y$$

does not send the vanishing sphere $k_* L_i$ back to L_i :

$$k^* k_* L_i \neq L_i$$

Instead, either computing it either from mirror symmetry,
or its via its definition coming from a Lagrangian correspondence,
one finds a figure eight Lagrangian

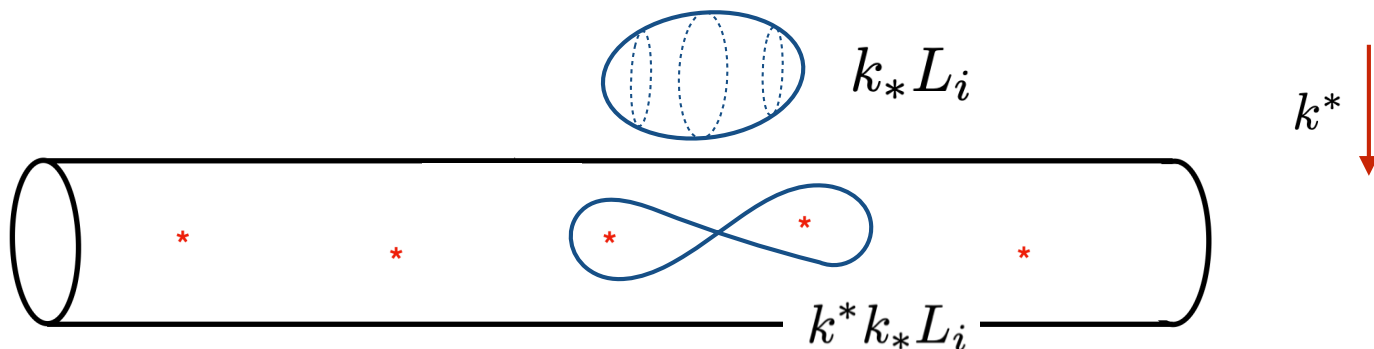

The basic virtue of the pair of adjoint functors,
 is that one ends up preserving Hom's.

$$\text{Hom}_{\mathcal{D}_Y}(k_*L_i, k_*L_j) = \text{Hom}_{\mathcal{D}_X}(k^*k_*L_i, L_j)$$

It is not difficult to see that this indeed is the case

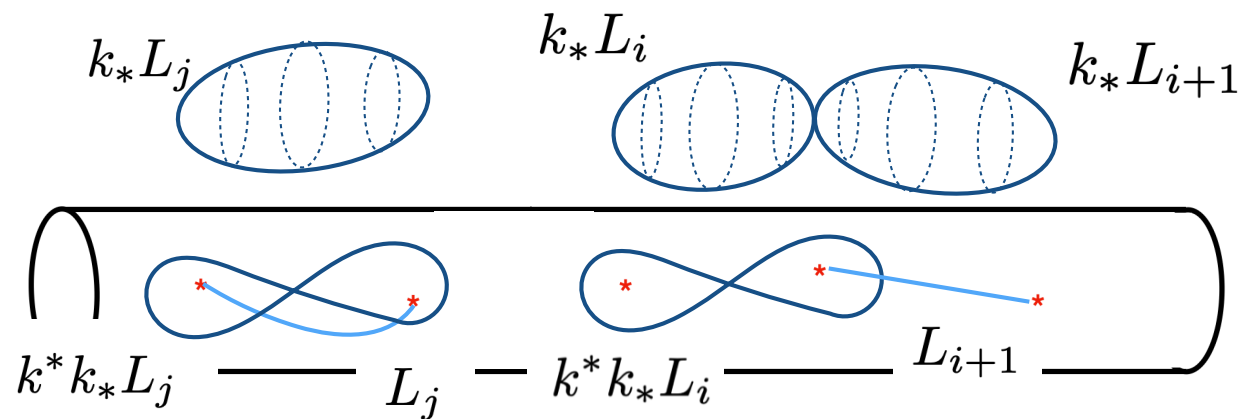

The example we just gave is relevant construction of

Khovanov homology,

since the needed \mathcal{Y} can be described as

$$\mathcal{Y} = \text{Sym}^m(A_{2m-1})^*$$

an open subspace in the symmetric product of

m copies of an A_{2m-1} surface:

$$uv = \prod_{I=1}^{2m} (x - a_I) \quad u, v \in \mathbb{C}, \quad x \in \mathbb{C}^\times$$

This

$$\mathcal{Y} = \text{Sym}^m(A_{2m-1})^*$$

is the same geometry Seidel and Smith studied
in their work on symplectic Khovanov homology,
as shown by Manolescu.

The corresponding Landau-Ginsburg model
has the target which is also an open subset of symmetric product,

$$Y = \text{Sym}^m(\mathcal{A})^*$$

of the surface where the conformal blocks live

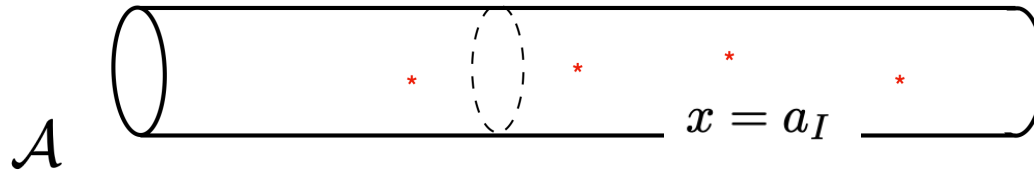

with potential

$$W_{LG} = \sum_{a=1}^m [x_a^\lambda + \sum_{I=1}^{2m} (1 - x_a/a_I)^{-1/\kappa} + \sum_{a \neq b} (1 - x_a/x_b)^{1/\kappa}]$$

The objects corresponding to top and the bottom

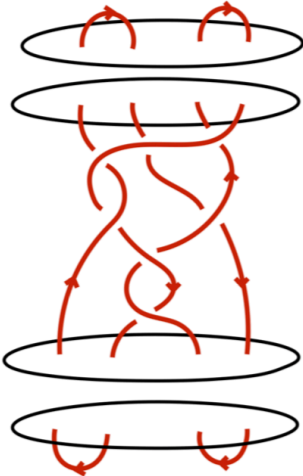

are the Lagrangians:

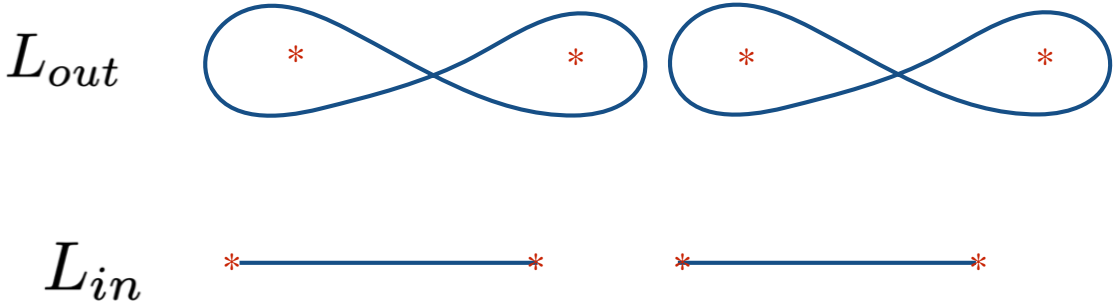

To get a non-trivial link, one starts by transporting L_{in} along the braid:

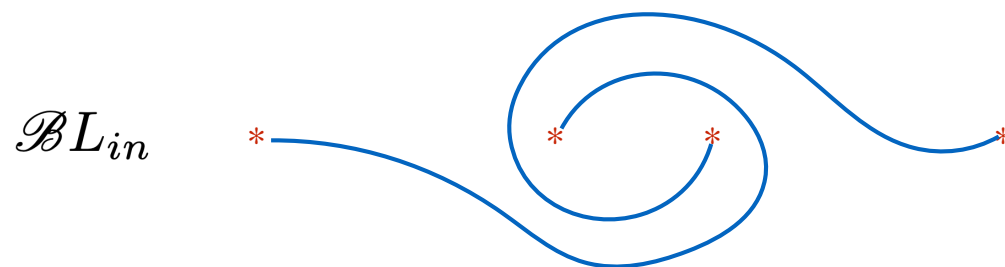

The generators of the Floer co-chain complex are the intersection points

$$p \in L_{out} \cap \mathcal{B}L_{in}$$

graded by the Maslov index, and the new grading that comes from the non-single valued super-potential.

The homological link invariant is the Floer cohomology group

$$HF^{*,*}(L_{out}, \mathcal{B}L_{in}) = \bigoplus_{n \in \mathbb{Z}, k \in \mathbb{Z}^{\text{rk}T}} \text{Hom}_{\mathcal{D}_Y}(L_{out}, \mathcal{B}L_{in}[n]\{k\})$$

whose differential is obtained by counting holomorphic disks of Maslov index one on Y , as in Floer's theory.

The condition that the disk is in Y requires W_{LG} to be single valued around the boundary of the disk, so equivariant grade of the differential is zero.

The Euler characteristic of the theory

simply counts the intersection points keeping track of gradings.

$$\chi(L_{out}, \mathcal{B}L_{in}) = \sum_{\mathcal{P} \in L_{out} \cap \mathcal{B}L_{in}} (-1)^{F(\mathcal{P})} q^{J(\mathcal{P})}$$

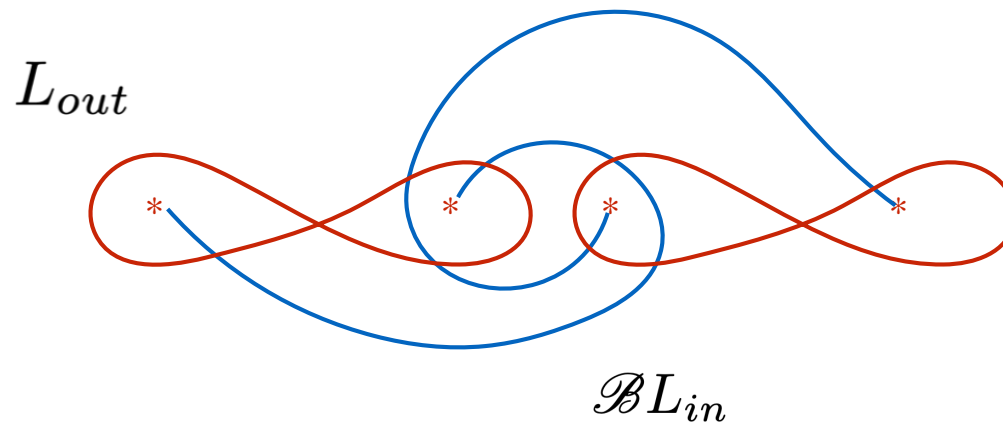

The result is the geometric explanation for the construction of Jones polynomial due to Bigelow, and a proof it categorifies the Jones polynomial.

In the remaining time,
let me try to explain the string theory origin of this construction.

The two dimensional theories we have been
discussing originate directly from string theory.

A helpful observation is another interpretation of

$$\mathcal{X}$$

In addition to being a resolution of
intersection of slices in the affine Grassmannian

$$\mathcal{X} = \text{Gr}_{\nu}^{\vec{\mu}}$$

and the moduli space of singular G -monopoles,

\mathcal{X} is also a Coulomb branch of a three dimensional gauge theory.

The theory is a
three dimensional quiver gauge theory

with quiver Q

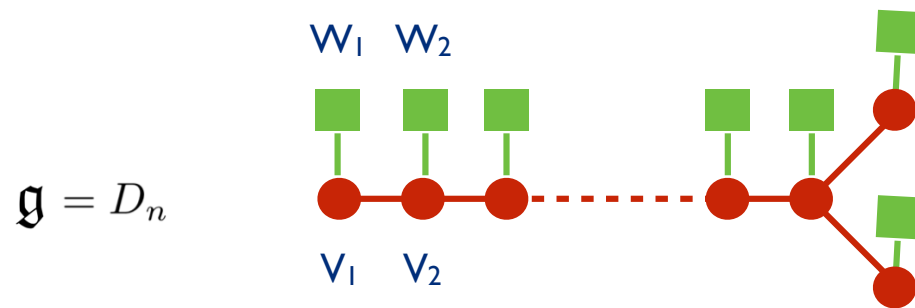

based on the Dynkin diagram of \mathfrak{g}

The ranks of the vector spaces

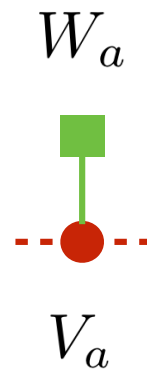

are determined from $\mu = |\vec{\mu}|$, ν in

$$\mathcal{X} = \text{Gr}_{\nu}^{\vec{\mu}}$$

This gauge theory arises on defects, or more precisely, on D-branes
of a six dimensional “little” string theory
labeled by a simply laced Lie algebra \mathfrak{g}

 $\mathfrak{g} = A_n$

 $\mathfrak{g} = D_n$

 $\mathfrak{g} = E_6$

 $\mathfrak{g} = E_7$

 $\mathfrak{g} = E_8$

with (2,0) supersymmetry.

The six dimensional string theory is
obtained by taking a limit of IIB string theory on an
ADE surface singularity of type

\mathfrak{g}

In the limit, one keeps only the degrees of freedom
supported at the singularity and decouples the 10d bulk.

One wants to study the six dimensional (2,0) little string theory on

$$M_6 \approx \mathcal{A} \times D \times \mathbb{C}$$

where

$$\mathcal{A} = S^1 \times \mathbb{R}$$

is the Riemann surface where the conformal blocks live,



$\mathbb{R} \times \mathbb{C}$ is the space where the monopoles live

and D is the domain curve of the 2d theories we had so far.

The vertex operators on the Riemann surface

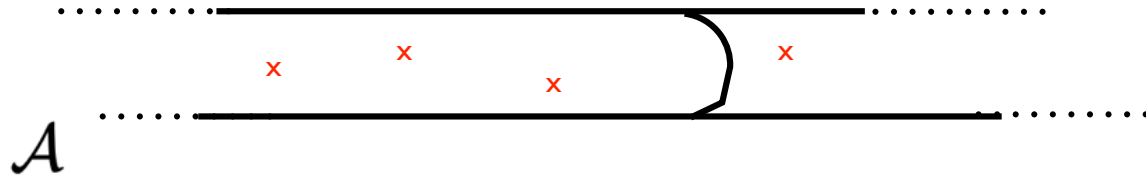

come from a collection of defects in the little string theory,
which are inherited from D-branes of the ten dimensional string.

The D-branes needed are

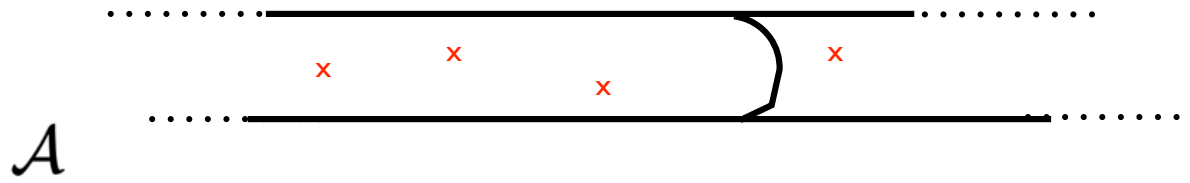

two dimensional defects of the six dimensional theory on

$$M_6 \approx \mathcal{A} \times D \times \mathbb{C}$$

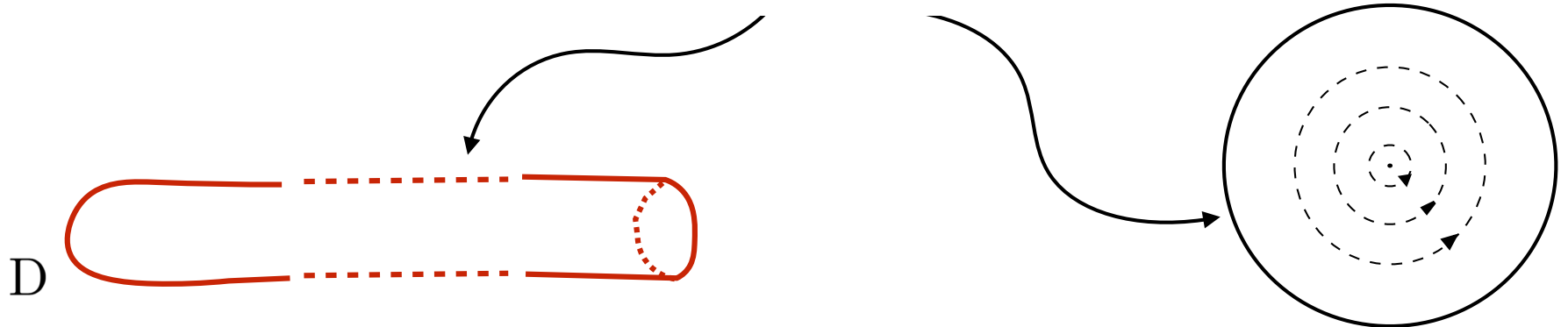

supported on D and the origin of \mathbb{C}

The theory on the D-branes is the quiver gauge theory

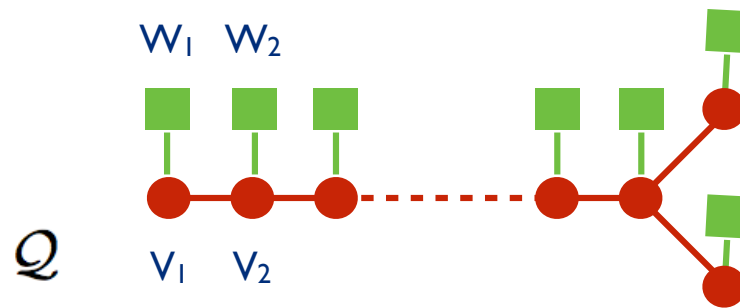

This is a consequence of the familiar description of
D-branes on ADE singularities
due to Douglas and Moore in '96.

The theory on the D-branes supported on D is a three dimensional quiver gauge theory on

$$D \times S^1$$

rather than a two dimensional theory on D , due to a stringy effect.

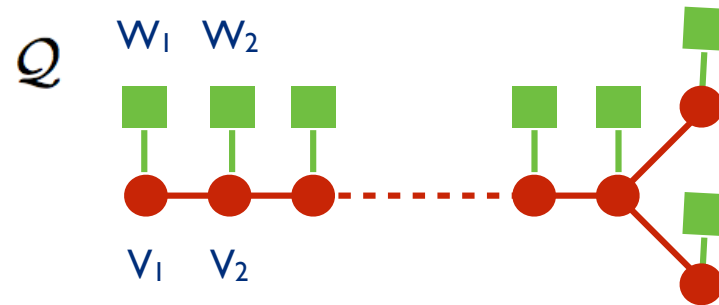

In a string theory,
 one has to include the winding modes of strings around \mathcal{A}

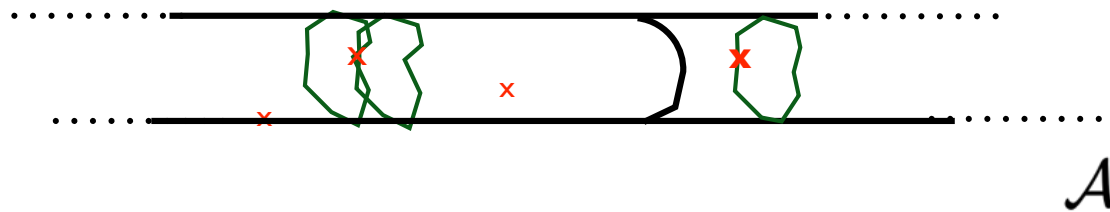

These turn the theory on the defects supported on D ,
 to a three dimensional quiver gauge theory on

$$D \times S^1$$

where the S^1 is the dual of the circle in \mathcal{A}

The same T-duality that makes the D-branes
three dimensional turns them into monopoles on

$$\mathbb{R} \times \mathbb{C}$$

of the T-dual six dimensional $(1, 1)$ string

which is a gauge theory.

The choice of vertex operators in

$$\langle \lambda | \Phi_{V_1}(a_1) \cdots \Phi_{V_\ell}(a_\ell) \cdots \Phi_{V_n}(a_n) | \lambda' \rangle$$

is the choice of D-branes of the little string.

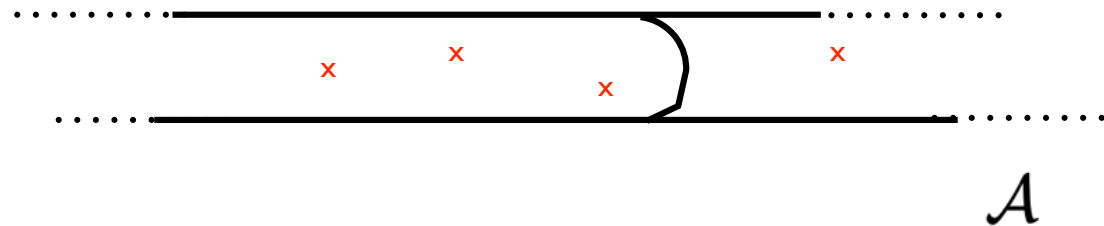

The choice of the Verma module state $\langle \lambda |$

is the choice of moduli of little string theory,

i.e. they are the expectation values of dynamical fields.

One can study the three dimensional theory on

$$D \times S^1$$

which comes from little string theory,

in much the same way

as we did the two dimensional theory.

The fact that the string scale is finite,
leads to a deformation of the structures
we had found, in particular, it breaks conformal invariance.

Rather than getting conformal blocks
and Knizhnik-Zamolodchikov equation,
from partition functions of the 3d theory on

$$D \times S^1$$

one obtains their deformation
corresponding to replacing

$$\widehat{L\mathfrak{g}} \longrightarrow U_{\hbar}(\widehat{L\mathfrak{g}})$$

affine Lie algebra

quantum affine algebra

Pursuing our story further,
rather than discovering knot invariants
we would discover integrable lattice models,
those of, in some sense, very general kind.

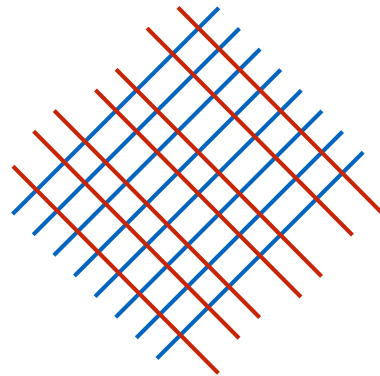

This story is developed in the work with Andrei Okounkov.

The six dimensional (2,0) string theory has a point particle limit

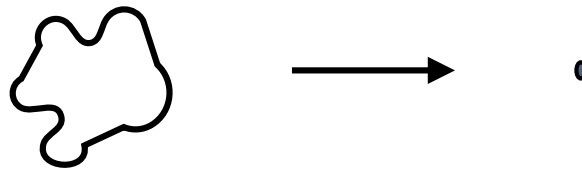

in which it becomes the six dimensional conformal field theory
of type \mathfrak{g}

This limit coincides with the conformal limit of the quantum affine algebra

$$U_{\hbar}(\widehat{L\mathfrak{g}}) \longrightarrow \widehat{L\mathfrak{g}}$$

In the point particle limit,

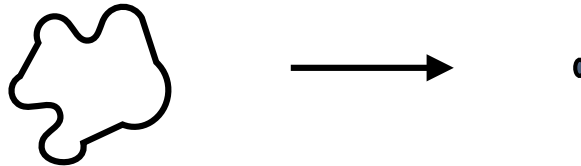

the winding modes that made the theory on the defects three dimensional, instead of two, become infinitely heavy.

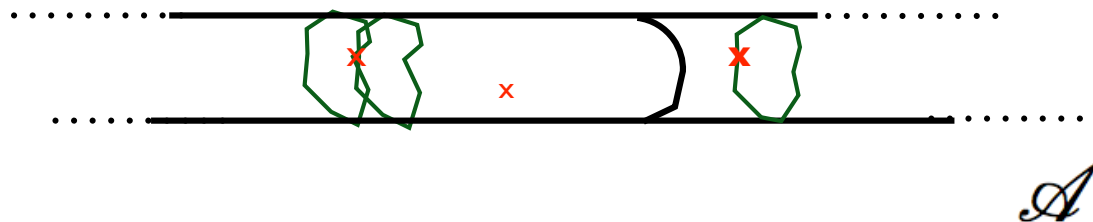

As a result, in the conformal limit, the theory on the defects becomes a two dimensional theory on D

It is surprising, but well understood that there are different two dimensional limits a three dimensional gauge theory can have.

The point particle limit of little string theory specifies which two dimensional limit of the three dimensional gauge theory on a circle we need to take.

The limit is called the “Coulomb branch reduction” as the one keeps the Kahler moduli of the Coulomb branch (but not of the Higgs branch) fixed.

The resulting theory is not a gauge theory in general,
but it has the two other descriptions,
I described earlier in the talk,
related by two-dimensional mirror symmetry.

There is a third description,
due to Witten.

It describes the same physics,
just from the bulk perspective.

Compactified on a very small circle,
the six dimensional \mathfrak{g} -type (2,0) conformal theory
with no classical description,
becomes a \mathfrak{g} -type gauge theory
in one dimension less.

To get a good 5d gauge theory description of the problem,
the circle one shrinks corresponds to S^1 in

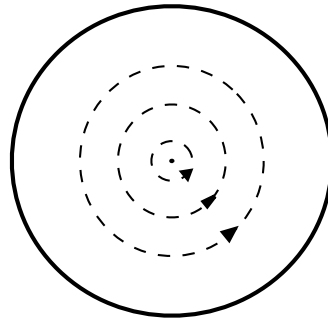

so from a six dimensional theory on

$$M_6 \approx \mathcal{A} \times D \times \mathbb{C}$$

one gets a five-dimensional gauge theory on a manifold with a boundary

The five dimensional gauge theory

has gauge group

$$G$$

which is the adjoint form of a Lie group with lie algebra \mathfrak{g} .

It is supported on

$$\widetilde{M}_5 = \widetilde{M}_3 \times D$$

where

$$\widetilde{M}_3 = \mathcal{A} \times \mathbb{R}_{\geq 0}$$

Our two dimensional defects become **monopoles**
of the 5d gauge theory on

$$\widetilde{M}_5 = \widetilde{M}_3 \times D$$

supported on D and at points on,

$$\widetilde{M}_3 = \mathcal{A} \times \mathbb{R}_{\geq 0} ,$$

along its boundary.

Witten shows that the five dimensional theory on

$$\widetilde{M}_5 = \widetilde{M}_3 \times D$$

can be viewed as a gauged

Landau-Ginzburg model on D with potential

$$\mathcal{W}_{\text{CS}} = \int_{\widetilde{M}_3} \text{Tr}(A \wedge dA + A \wedge A \wedge A)$$

on an infinite dimensional target space \mathcal{Y}_{CS}

corresponding to $\mathfrak{g}_{\mathbb{C}}$ connections on $\widetilde{M}_3 = \mathcal{A} \times \mathbb{R}_{\geq 0}$

with suitable boundary conditions (depending on the knots).

To obtain knot homology groups in this approach,
one ends up counting solutions to
certain five dimensional equations.

The equations arise in
constructing the Floer cohomology groups
of the five dimensional Landau-Ginzburg theory.

Thus, we end up with three different approaches
to the knot categorification problem,
all of which have the same
six dimensional origin.

They all describe the same physics
starting in six dimensions.

The two geometric approaches,
describe the physics from perspective of the defects that introduce knots
in the theory.

The approach based on the 5d gauge theory,
describes it from perspective of the bulk.

In general,
theories on defects
capture only the local physics of the defect.

In this case,
they capture all of the relevant physics,
due to a version of supersymmetric localization:
in the absence of defects,
the bulk theory is trivial.